

Location: _____



F300

7" ROUND HEELPROOF ADJUSTABLE AREA DRAIN

Specification: MIFAB Series F300 light commercial lacquered area drain with anchor flange, primary and secondary weepholes, and standard 1" (25) thick, 7" (178) round, heelproof, adjustable ductile iron grate.

Function: Used in warehouses, mechanical rooms, parking garages and other membrane finished areas. 7" Round, adjustable tractor grate is used with all types of poured finished floors.

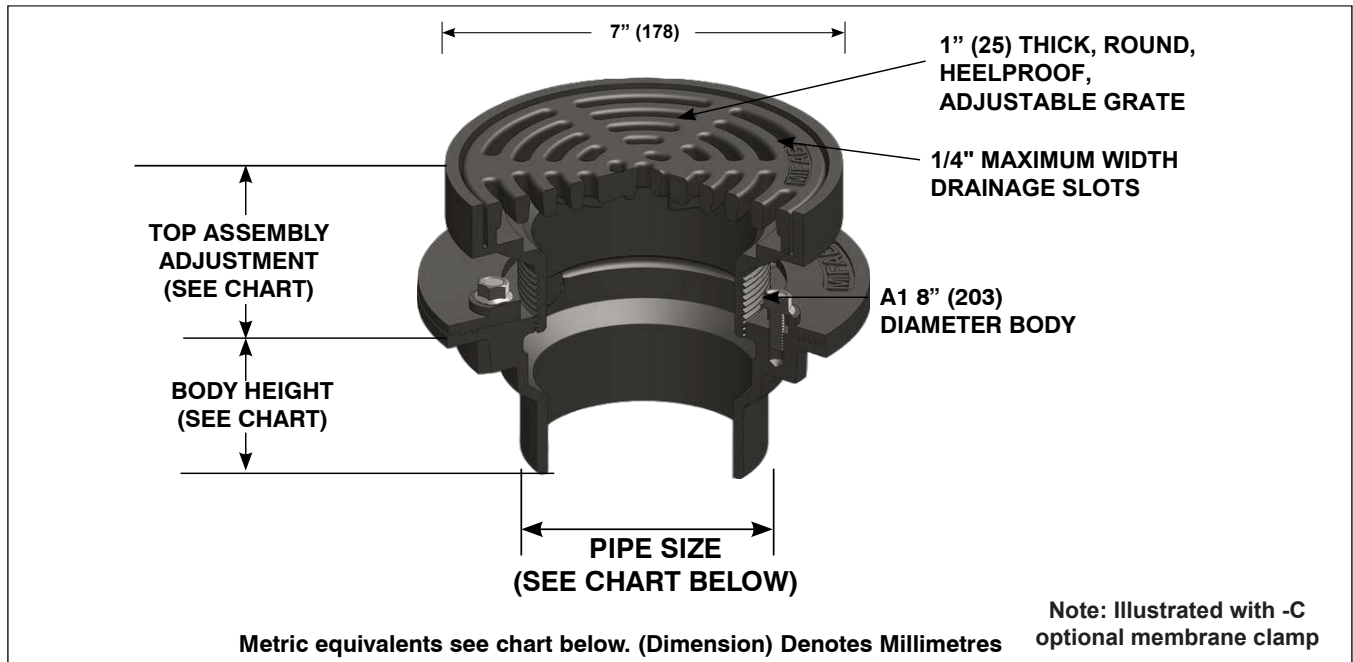

Metric equivalents see chart below. (Dimension) Denotes Millimetres

STRAINER DIAMETER	STRAINER ADJUSTMENT		PIPE SIZE	BODY HEIGHT		
	MIN	MAX		NO HUB (STANDARD)	PUSH ON (P)	PVC/ABS (-30)/(-31)
7" (178)	1 5/8" (41)	2 5/8" (67)	2" (51)	4" (102)	4 3/8" (111)	4 3/8" (111)
			3" (76)	4" (102)	4 3/8" (111)	4 3/8" (111)
			4" (102)	4" (102)	4 3/8" (111)	4 3/8" (111)

SUFFIX	OPTIONAL VARIATIONS
-5	Sediment Bucket
-6	Vandal resistant screws (H-1072 - 1 piece)
-69	Stainless Steel Sediment Bucket
-C	Membrane Clamp (included with F330)
-F4-1	4" Round Nickel Bronze Funnel
-F4-50	4" Round cast Iron Funnel
-G-1	4" x 9" Oval Nickel Bronze Funnel
-G-50	4" x 9" Oval cast Iron Funnel

Job Name: _____ Page No: _____
 Section No: _____ Contract: _____
 Schedule No: _____ Purchase Order No: _____