

Location: \_\_\_\_\_



**F100**

**ROUND ADJUSTABLE FLOOR DRAIN WITH FLANGE**

**Specification:** MIFAB Series F100 lacquered cast iron floor drain with anchor flange, and standard satin finished nickel bronze or ductile iron strainer with vandal resistant stainless steel allen key screws. Trap Seal Primer tapping included with all bodies.

**Function:** Used in showers, kitchens, restrooms, and other non-membrane finished areas.

**F104-30-5-1**

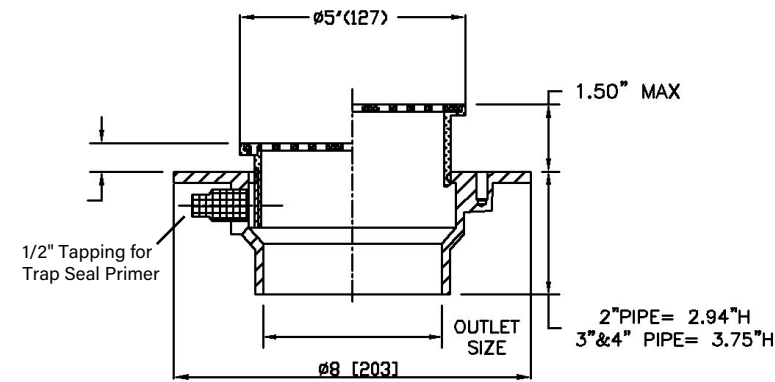
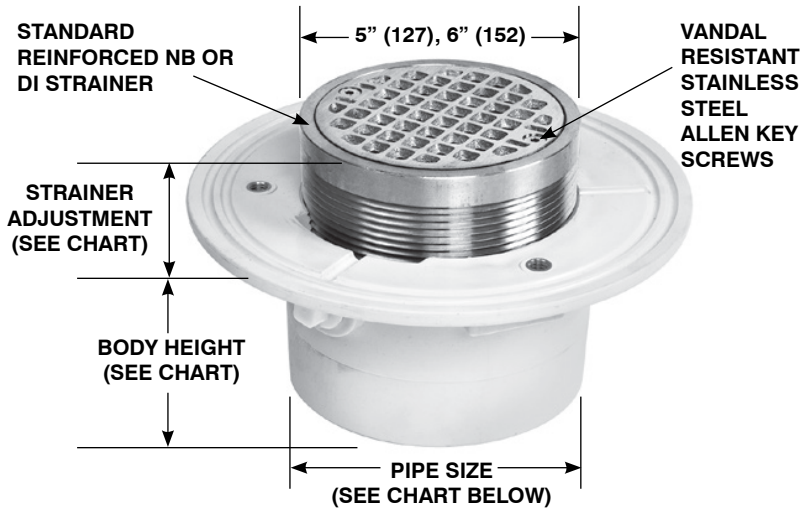

**F104-5-1**

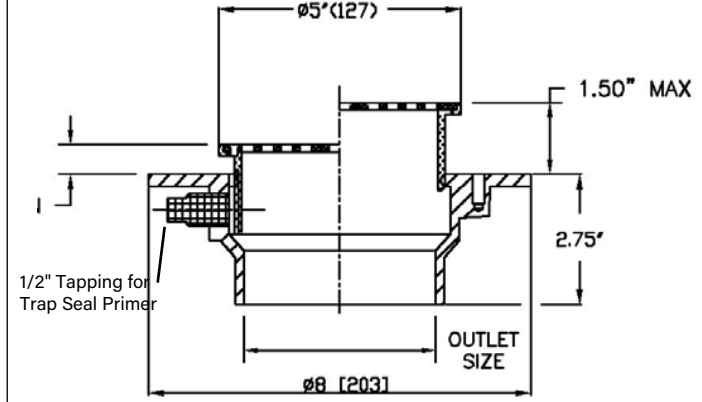
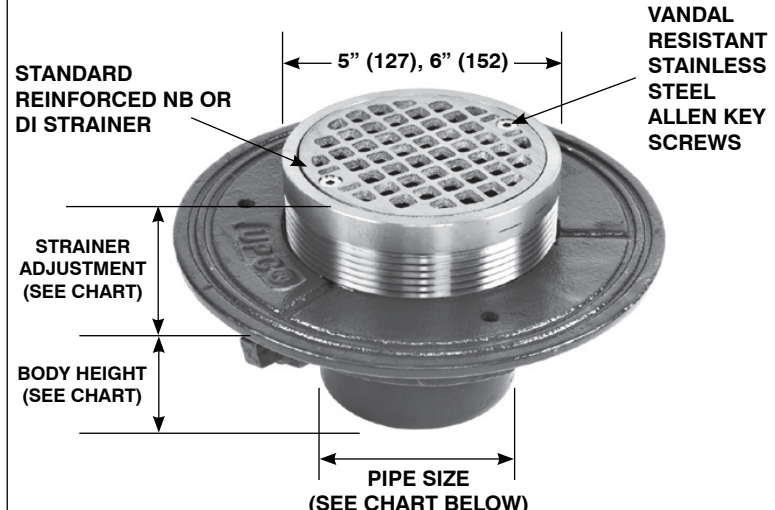

STRAINER DIAMETER	STRAINER ADJUSTMENT		PIPE SIZE	NO HUB (STANDARD)	PUSH ON (P)	PVC/ABS (-30)/(-31)
	MIN	MAX				
5" (127)	1/2" (13)	1 1/2" (38)	2" (51)	3" (76)	3 3/8" (86)	2 15/16" (75)
6" (152)	11/16" (17)	1 1/2" (38)	3" (76)	3" (76)	3 3/8" (86)	3 3/4" (95)
			4" (102)	3" (76)	3 3/8" (86)	3 3/4" (95)

**SUFFIX OPTIONAL VARIATIONS**

- 4 Ductile Iron Grate
- 6 Vandal proof

Job Name: \_\_\_\_\_  
 Section No: \_\_\_\_\_  
 Schedule No: \_\_\_\_\_

Page No: \_\_\_\_\_  
 Contract: \_\_\_\_\_  
 Purchase Order No: \_\_\_\_\_