

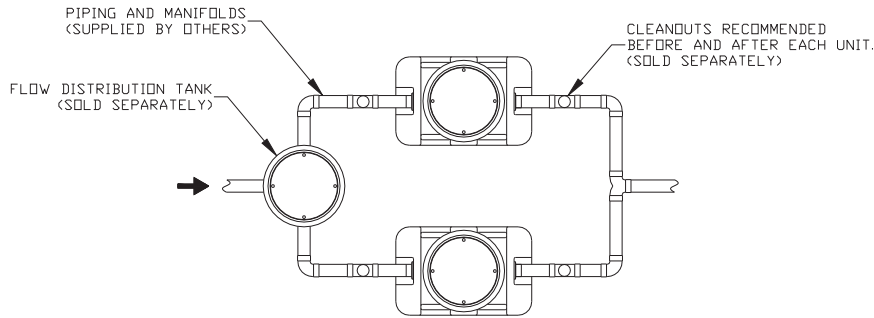

# XL-MI-G-PL PARALLEL

# BIG MAX INTERCEPTOR IN PARALLEL

**Specification:** MIFAB® Series XL-MI-G-PL parallel installation of multiple Mig Max units for higher grease storage and flow rate requirements. It is recommended to install a cleanout prior to the first unit, after the last unit, and between each unit if long runs of pipe are required.



XL-MI-G-PL-750 TWO IN PARALLEL  
10 GPM, 1500 GREASE LBS. CAPACITY

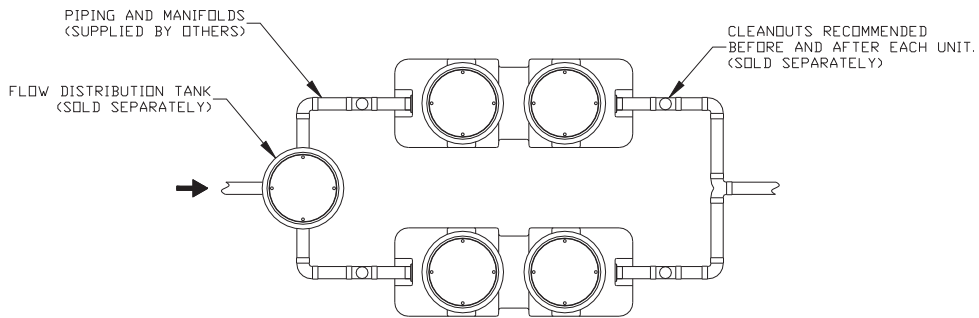

XL-MI-G-PL-1150 TWO IN PARALLEL  
200 GPM, 2300 GREASE LBS. CAPACITY

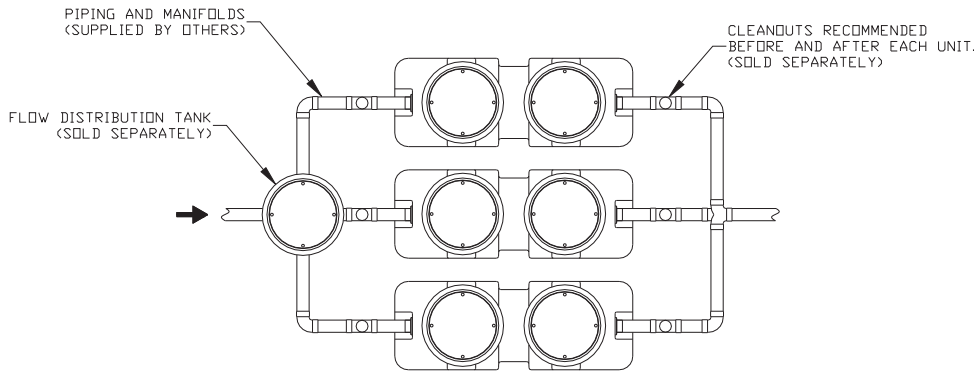

XL-MI-G-PL-1150 THREE IN PARALLEL  
300 GPM, 3450 GREASE LBS. CAPACITY

Job Name: \_\_\_\_\_  
Section No: \_\_\_\_\_  
Schedule No: \_\_\_\_\_

Page No: \_\_\_\_\_  
Contractor: \_\_\_\_\_  
Purchase Order No: \_\_\_\_\_