

BIG-1150

- 1. Inlet and Outlet No-Hub Connections.
- 2. Liquid Holding Capacity: 300 Gallons
- 3. H2O Load Rated Access Covers
- 4. Maximum Operating Temperature: 190Å Continuous

DETAILS

- Certified by CSA and IAPMO to ASME A112.14.3, CSA B481
- Approved installation to ASME A112.14.3 Type C
- Factory installed internal piping.
- 3/8" thick seamless high density polyethylene.
- Full internal access through lids.
- Vent not required for proper operation.
- Designed for above or below ground installations.
- Integral Anti-siphon Air Relief port.

SUFFIX

- AK
- C
- DP
- EP
- F6
- HLA

OPTIONAL VARIATIONS

- High water anchor kit
- Lid extension(specify)
- Dosing pump
- Enzyme port
- 6" No Hub inlet/outlet connection
- High level alarm

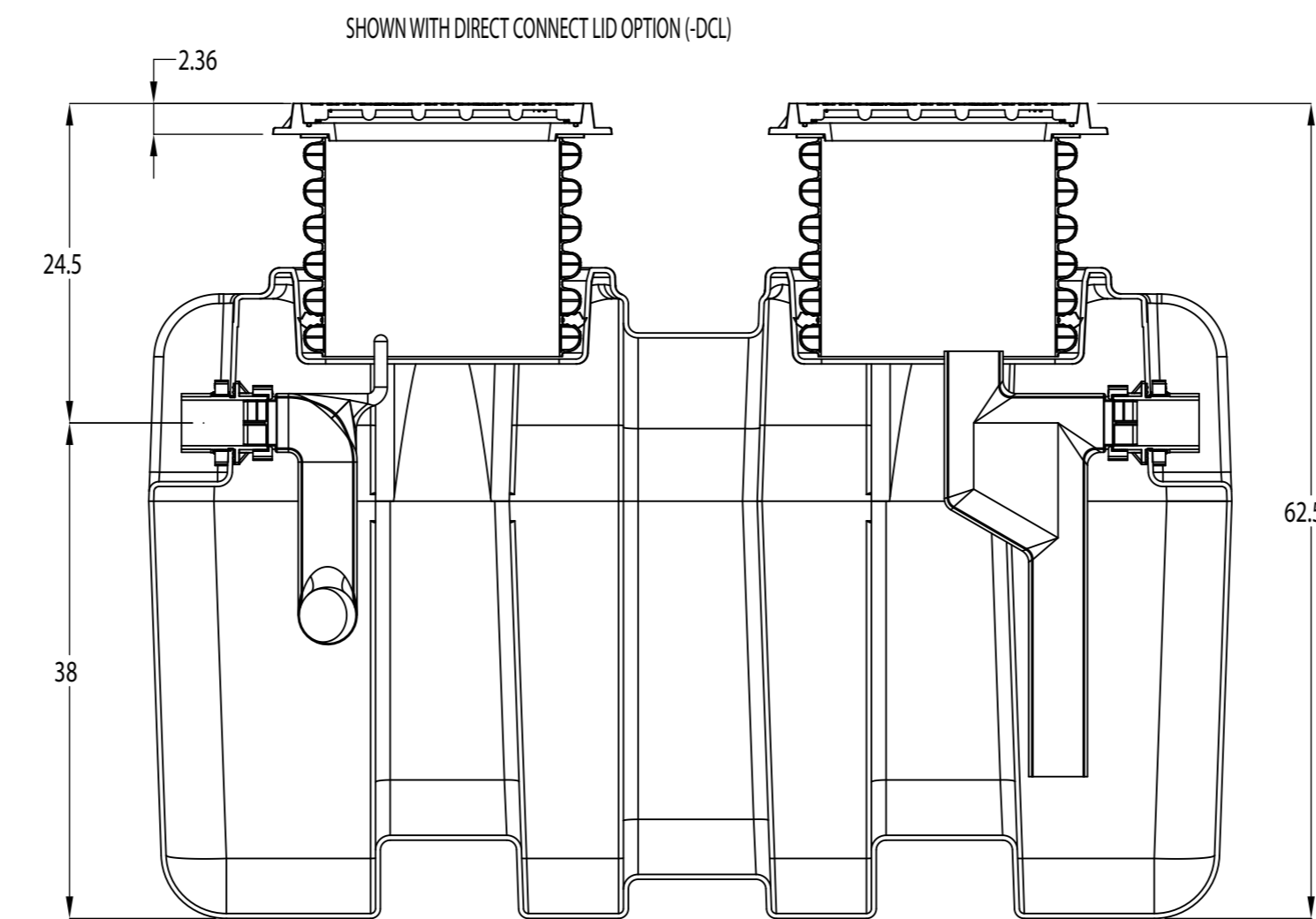
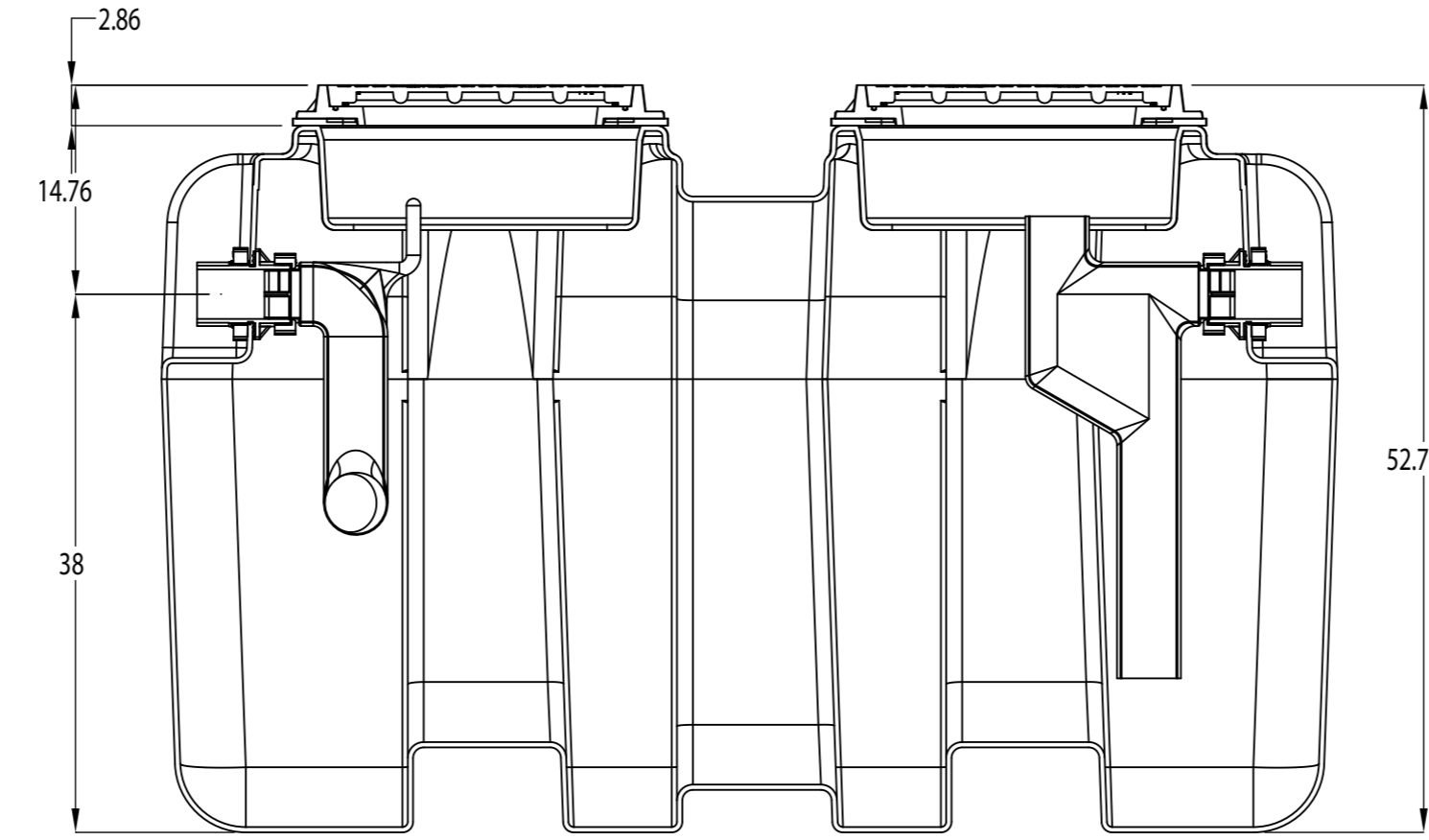
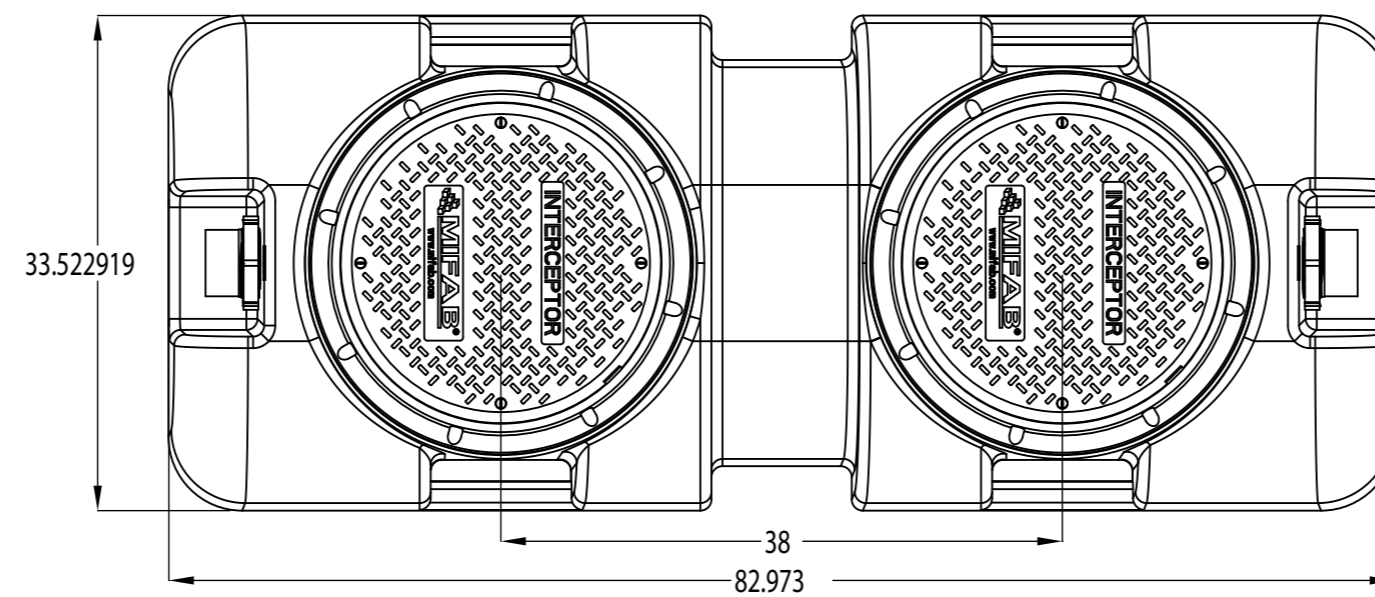
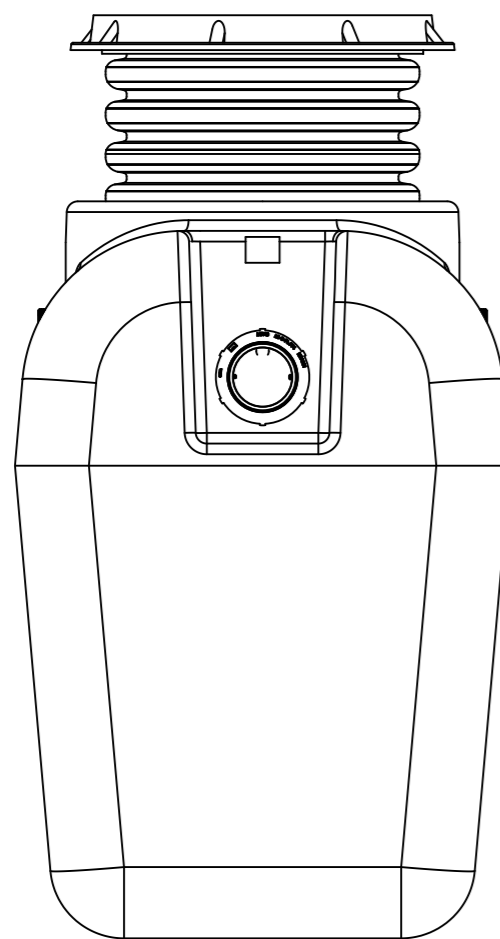
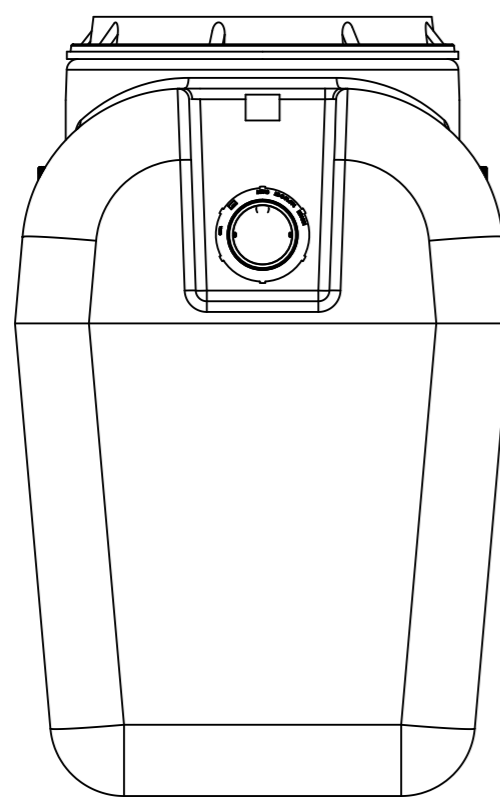

SHOWN WITH DIRECT CONNECT LID OPTION (-DCL)

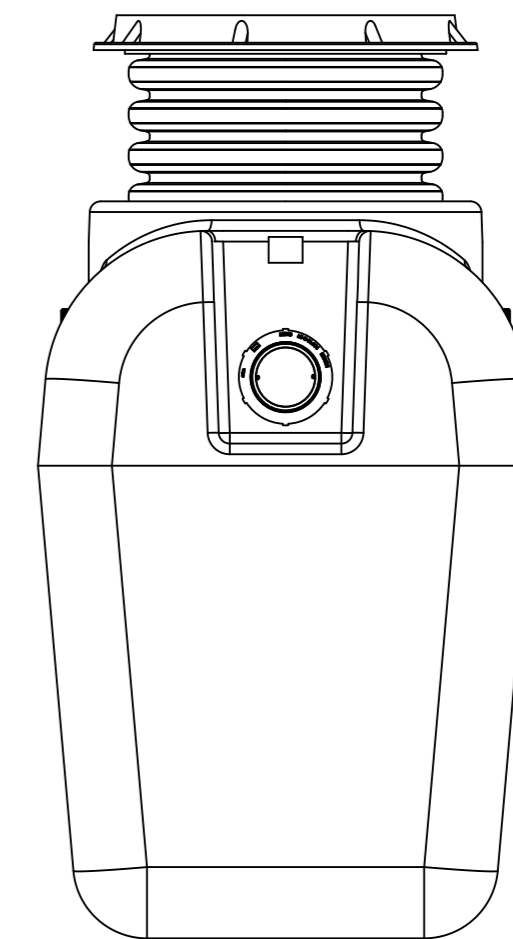
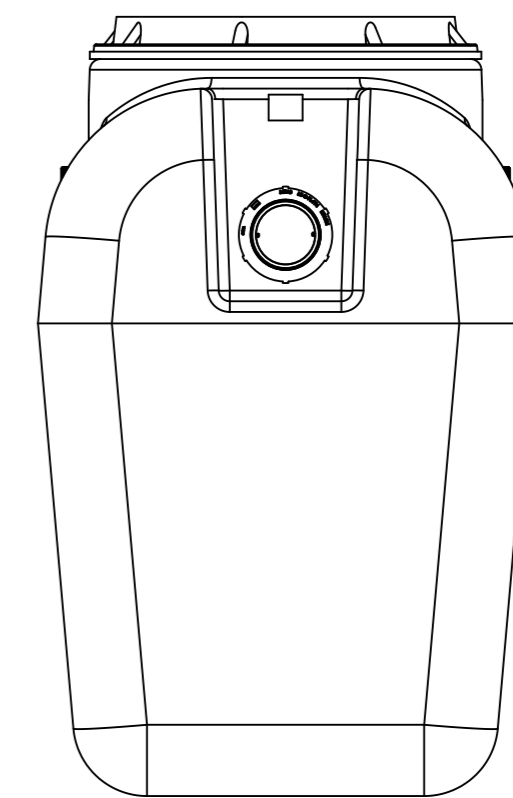

PROPRIETARY AND CONFIDENTIAL
THE INFORMATION CONTAINED IN THIS DRAWING IS THE SOLE PROPERTY OF MIFAB, INC. ANY REPRODUCTION IN PART OR AS A WHOLE WITHOUT THE WRITTEN PERMISSION OF MIFAB, INC. IS PROHIBITED.

LASER/SHEAR:		UNLESS OTHERWISE SPECIFIED: DIMENSIONS ARE IN INCHES TOLERANCES: FRACTIONAL ± 1/16 ANGULAR: MACH ± 1 Å BEND ± 1 Å TWO PLACE DECIMAL ± .015 THREE PLACE DECIMAL ± .010 TYPICAL DRAFT ANGLE 2 Å MATERIAL DESCRIPTION: SEE-BOM FINISH PART: CLEAN DO NOT SCALE DRAWING	NAME	DATE	TITLE: 100 GPM HDPE GREASE INTERCEPTOR SIZE C DWG. NO. BIG-1150 REV SCALE: 1:13 WEIGHT: SHEET 1 OF 1	
BRAKE PRESS:			DRAWN	XX		XX
WELDED BY:			CHECKED			XX
CLEAN/PAINT:			ENG APPR.			
COMPLETED BY:			MFG APPR.			
REVIEWED BY:			Q.A.			
NEXT ASSY	USED ON	APPLICATION	QUANTITY: SEE-PO#			