

Location: _____



PRV-C

WATER PRESSURE REDUCING VALVES COMPACT -LL

Specification: A Water Pressure Reducing Valve with a built in strainer shall be installed in the incoming water line where supply main pressure exceeds 60psi (413 kPa). The Pressure Reducing Valve shall consist of a bronze body and metal cap, and shall have an adjustment screw to allow adjusting the pressure down to 50PSI (345 kPa), and shall be designed for incoming pressures up to 300 PSI (20.7 bar). The device must have a built in strainer that will stop debris from entering the pressure reducing chamber and is removable for cleaning. Valve shall be of the balanced piston design and shall reduce pressure in both flow and no-flow conditions.

Ratings:

Temperature Range: 33° F - 180° F (0.5° C - 82° C).
 Maximum Working Pressure: 300 P.S.I. (20.7 bar).
 Adjustable Pressure Range: 25-75 P.S.I. (172 - 517 kPa).
 Standard Reduced Pressure Setting: 50 P.S.I. (345 kPa).

Materials:

Body and Cage: ASTM B 584 (copper construction)
 Integral Strainer: Stainless Steel
 Valve Disk: Elastomer
 Diaphragm: Reinforced EPDM
 Seat: Engineered Polymer

Features:

Internal Bypass for Thermal Expansion.
 Convenient Strainer and Seat Access. In-line serviceability.
 Corrosion Resistant Body and Cover.
 Single or Double Union Connection.
 Stainless Steel Strainer.

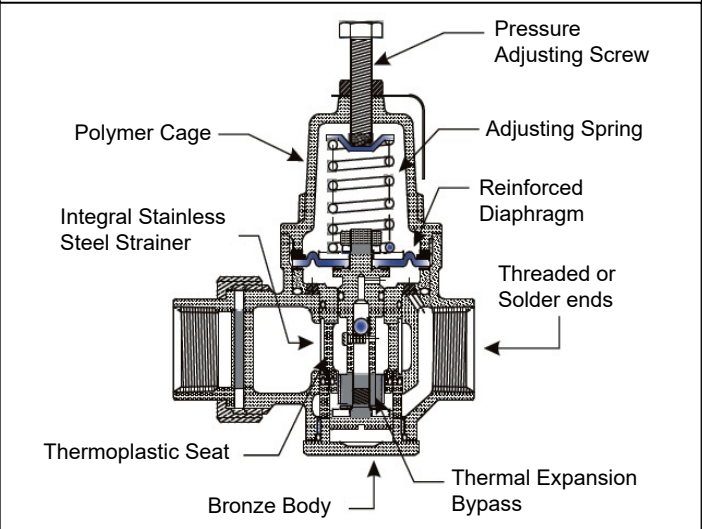
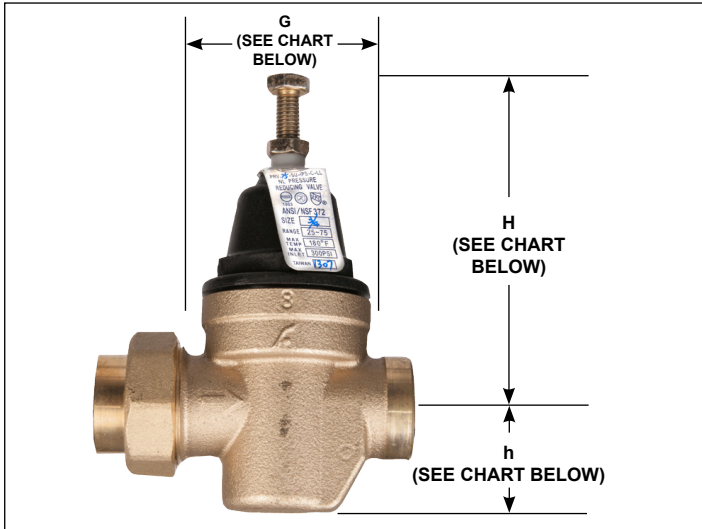
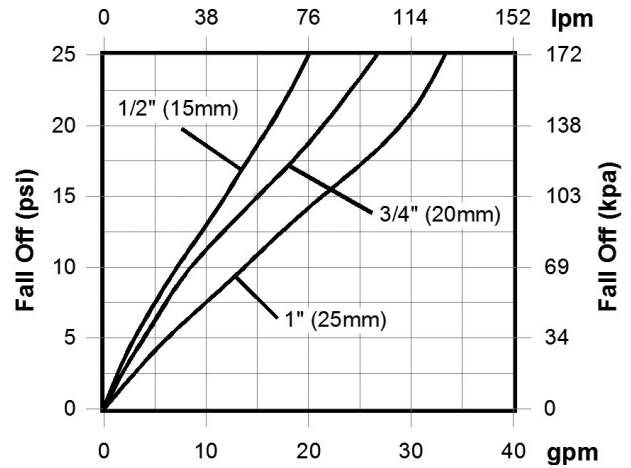

Size	Model Number					H	h	G
	SU-IPS-C	DU-IPS-C	SU-SWT-C	DU-SWT-C	DU-PEX-C			
1/2" (13)	PRV.50-SU-IPS-C-LL 4.02" (120)	PRV.50-DU-IPS-C-LL 5.28" (134)	PRV.50-SU-SWT-C-LL 3.80" (97)	PRV.50-DU-SWT-C-LL 4.84" (123)	PRV.50-DU-PEX-C-LL 4.96" (126)	3.94" (100)	1.30" (33)	2.19" (56)
3/4" (19)	PRV.75-SU-IPS-C-LL 4.02" (120)	PRV.75-DU-IPS-C-LL 5.28" (134)	PRV.75-SU-SWT-C-LL 4.06" (103)	PRV.75-DU-SWT-C-LL 5.34" (136)	PRV.75-DU-PEX-C-LL 4.96" (126)	3.94" (100)	1.30" (33)	2.19" (56)
1" (25)	PRV1.00-SU-IPS-C-LL 4.61" (117)	PRV1.00-DU-IPS-C-LL 5.87" (149)	PRV1.00-SU-SWT-C-LL 6.28" (160)	PRV1.00-DU-SWT-C-LL 6.28" (160)	PRV1.00-DU-PEX-C-LL 5.91" (150)	4.96" (126)	1.30" (33)	2.75" (70)



Approvals:
 Valve is tested and certified to A.S.S.E. Standard 1003 (ANSI A 112.26.2), listed with I.A.P.M.O. and certified to CSA Standard B356

CALIFORNIA PROPOSITION 65 WARNING: This product contains chemicals known to the State of California to cause cancer and birth defects or other reproductive harm.

Job Name: _____ Page No: _____
 Section No: _____ Contractor: _____
 Schedule No: _____ Purchase Order No: _____