

Location:



DCDA

2 1/2" THRU 10" DOUBLE CHECK DETECTOR ASSEMBLIES

Specification: The BEECO Friendly Double Check Detector Assembly is designed to stop the reverse of flow of a liquid into a potable water system. The proper installation of a backflow preventer must be done by a certified expert under local codes and guidelines to assure the protection of the drinking water system. The Valve shall be certified to ASSE 1048, CSA B64.5 and IAPMO listed. Certified lead free devices.

Function: The assembly shall consist of two repairable positive seating check modules with captured springs and rubber seat discs. Service of all internal components shall be through a single easily removable cover and designed for ease of access.

Features: Single access cover for fast service, Swing away clamp for ease of removing checks, Modular design reducing number of spare parts, Self contained check so there is no pressure to relieve when changing the seats.

Ratings: Maximum working water pressure 175 PSI, Working temperature range 33°F-140°F. Hydrostatic test pressure 350 PSI, Flanged end connection meet ANSI B16.1 and all grooved dimensions comply with AWWA C606

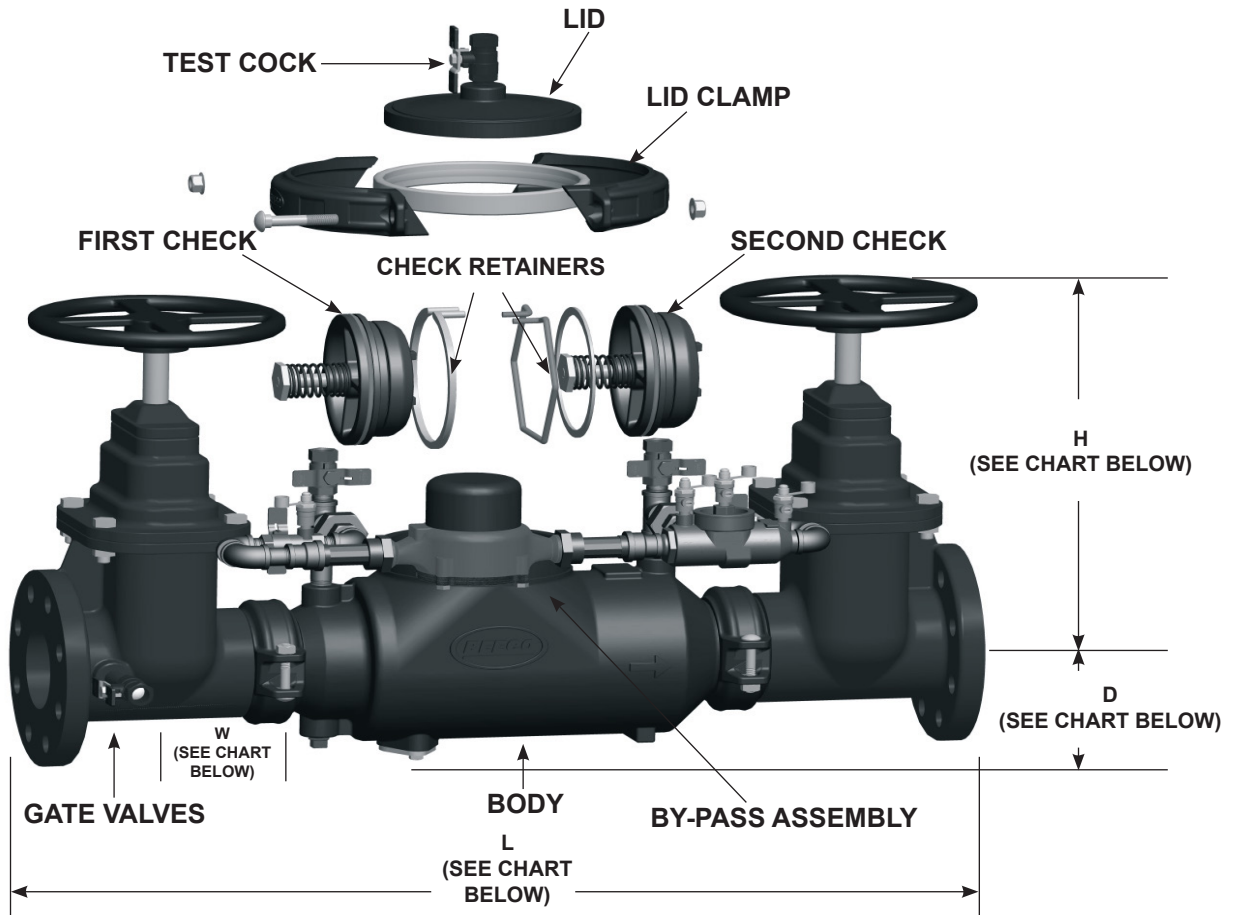

Model No.	L	H OSY	H NRS	D	W	Flange Bolt Torque (ft.-lbs.)
FDC2.50-OSY-DCDA	33.5	18.88	16.38	7.00	10.10	70
FDC3.00-OSY-DCDA	34.5	21.88	18.88	7.50	10.10	70
FDC4.00-OSY-DCDA	40.8	25.63	21.63	9.00	10.10	75
FDC6.00-OSY-DCDA	43.8	35.13	29.13	11.00	10.10	130
FDC8.00-OSY-DCDA	56.5	44.63	36.63	13.50	17.95	130
FDC10.00-OSY-DCDA	59.5	54.5	44.5	16.00	17.96	180

Job Name: <input type="text"/>	Page No.: <input type="text"/>
Section No.: <input type="text"/>	Contract: <input type="text"/>
Schedule No.: <input type="text"/>	Purchase Order No.: <input type="text"/>

Location:



DCDA

2 1/2" THRU 10" DOUBLE CHECK DETECTOR ASSEMBLIES

***Valves Approved for Horizontal or Vertical Up Orientation.**

