

MIFAB CLEANOUT FEATURES

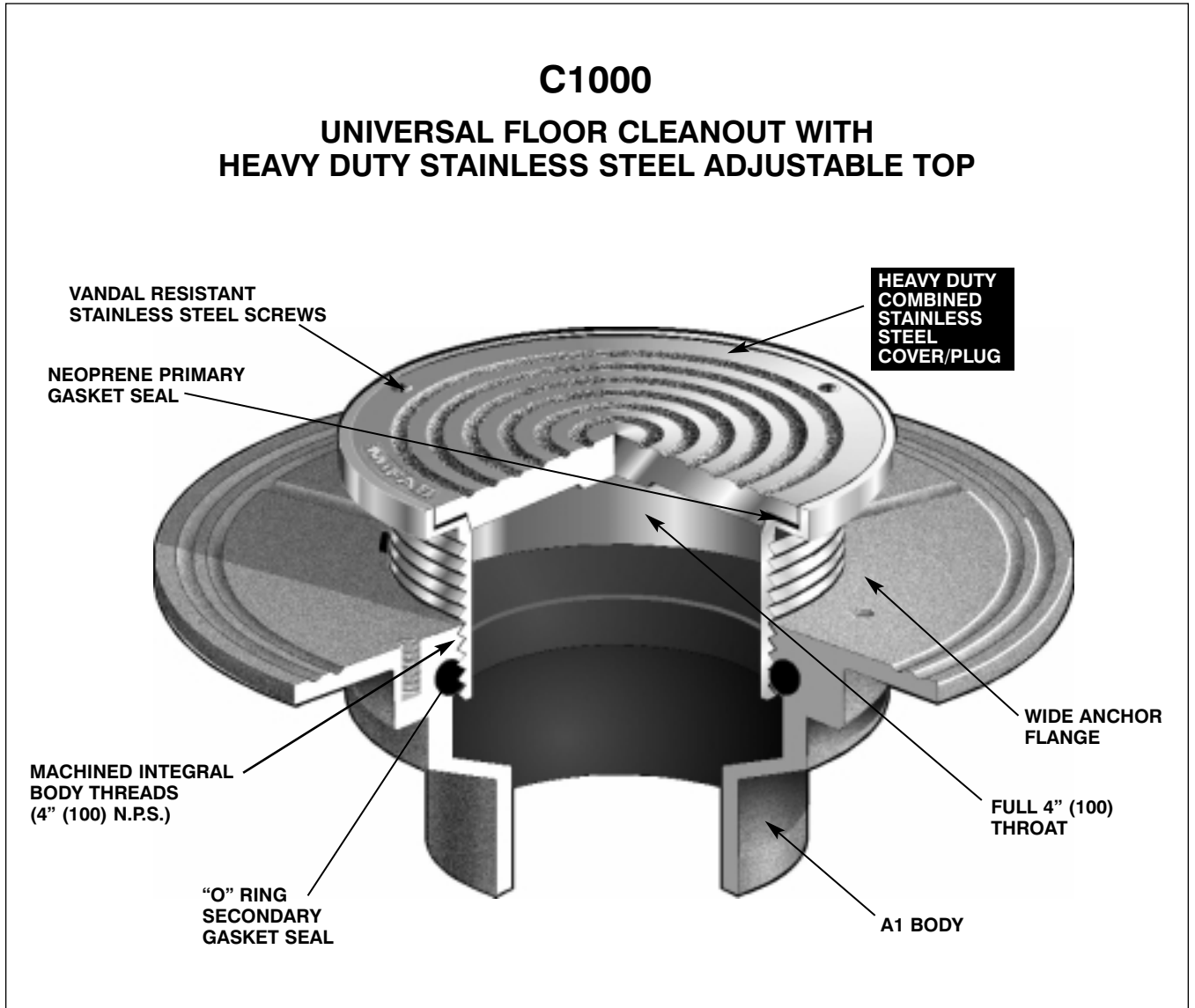

C1000, C1100 SERIES HAVE BEEN TESTED AND CERTIFIED TO THE ANSI/ASME CLEANOUT STANDARD A112.36.2M-1991 AND ARE LISTED WITH I.A.P.M.O.