

Location: \_\_\_\_\_



**T200-PGC-3-MU-500**

**Stainless Steel Maintenance Unit Paverslot  
Grate to suit 8" clear opening channels**

**Specification:** T200-PGC-3-MU-500 stainless steel paverslot grates are independently certified to meet Load Class C tested in accordance with EN 1433 (56,200 lbs. (250kN). The grate length is 19.7" (.5 m). The grates utilize the patented "Clipfix" grate locking mechanism. The system (channel and grate) provides longitudinal shift protection.

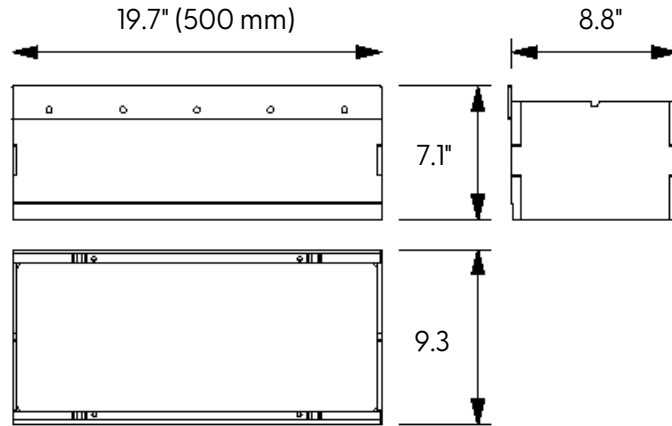

**Grate Free Area**  
**T200-PGC-3-MU-500**  
.01 Sq. in./ft.



**CLIPFIX ADVANTAGE**

The MEA polymer concrete and GRP channels are designed for our universal CLIPFIX grate locking mechanism. The system (channel and grate) provides longitudinal shift protection.

GRATE MODEL NUMBER	LENGTH
T200-PGC-3-MU-500	19.7" (500 mm)

LOAD CLASS C		Compliance	
 <b>MEA</b> BUILDING SUCCES	 EN 1433 - 56,200 LBS., 250kN, 1160 PSI	 ADA	 HEELPROOF

CALIFORNIA PROPOSITION 65 WARNING. This product contains chemicals known to the State of California to cause cancer and birth defects or other reproductive harm.

Job Name: \_\_\_\_\_  
 Section No: \_\_\_\_\_  
 Schedule No: \_\_\_\_\_

Page No: \_\_\_\_\_  
 Contractor: \_\_\_\_\_  
 Purchase Order No: \_\_\_\_\_