

Location: _____



T100-PGC-3-SD

Stainless Steel Paverslot Grate to suit 4" clear opening channels

Specification: T100-PGC-3-SD stainless steel paver-slot grates are independently certified to meet Load Class C tested in accordance with EN1433 (56,200 lbs. 250kN). The grate length is 39.4" (1 m). Optional (.5 m) grates are also available in Load Class C (Part # T100-PGC-3-SD-500).

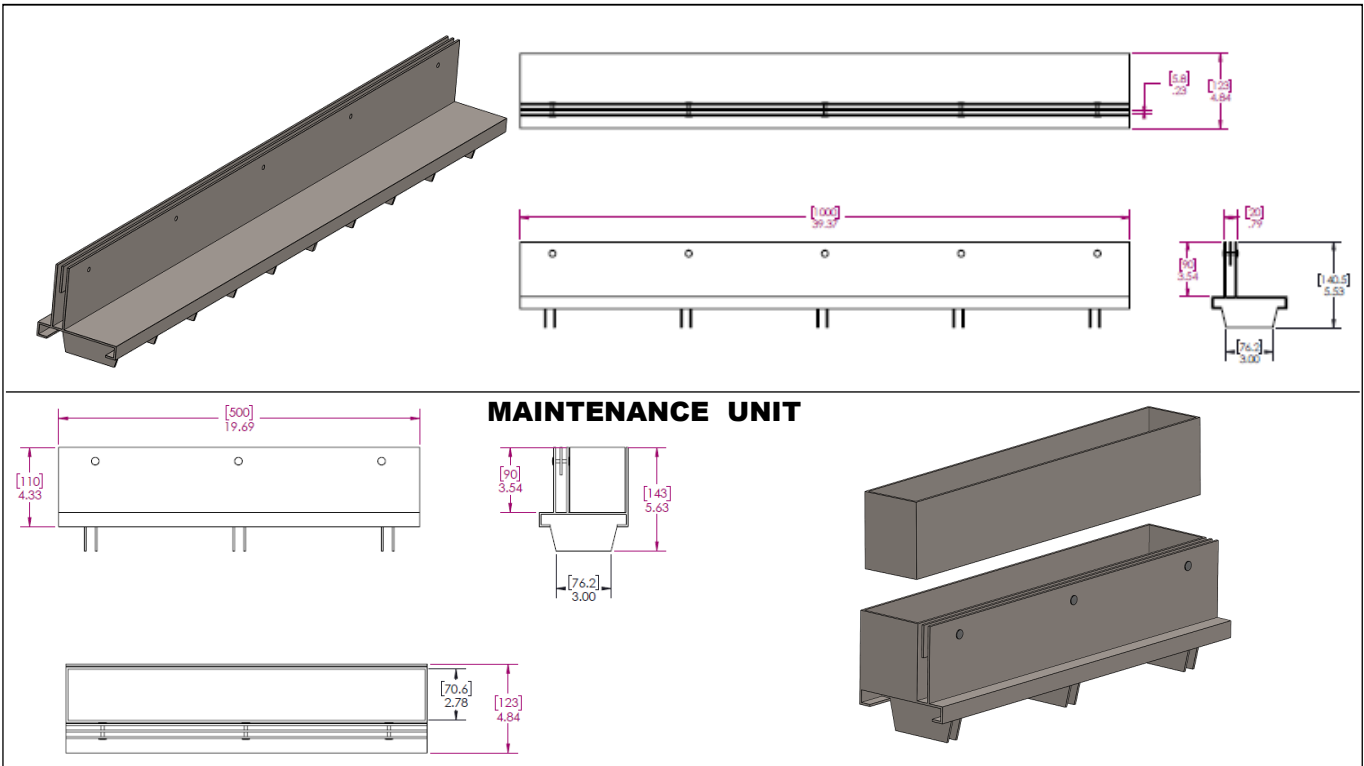

GRATE MODEL NUMBER	LENGTH
T100-PGC-3-SD	39.4" (1000 mm)
T100-PGC-3-SD-500	19.7" (500 mm)
T100-PGC-3-MU-500	19.7" (500 mm)

COMPLIANCE		LOAD CLASS C
 BUILDING SUCCESS	 ADA	 HEELPROOF
		 EN 1433 - 56,200 LBS., 250kN, 1,160 PSI

CALIFORNIA PROPOSITION 65 WARNING. This product contains chemicals known to the State of California to cause cancer and birth defects or other reproductive harm.

Job Name: _____ Page No: _____
 Section No: _____ Contractor: _____
 Schedule No: _____ Purchase Order No: _____

MIFAB® reserves the right to make changes in material and design without formal notice and obligation.

USA: 1-800-465-2736 www.mifab.com CAN: 1-800-387-3880