

Location:



## Galvanized Steel Longitudinal Grate to suit 4" clear opening channels



**Specification:** T100-PGB-13-LS galvanized steel longitudinal grates are independently certified to meet Load Class B tested in accordance with EN 1433 (28,100 lbs. (125kN)). The grate length is 39.4" (1 m). The grates utilize the patented "Clipfix" grate locking mechanism. The system (channel and grate) provides longitudinal shift protection. Optional .5 meter grates are also available in Load Class B (Part # T100-PGB-13-LS-500).

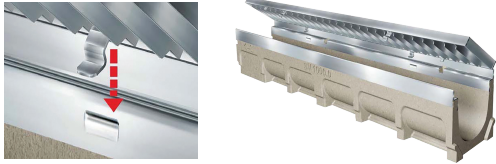
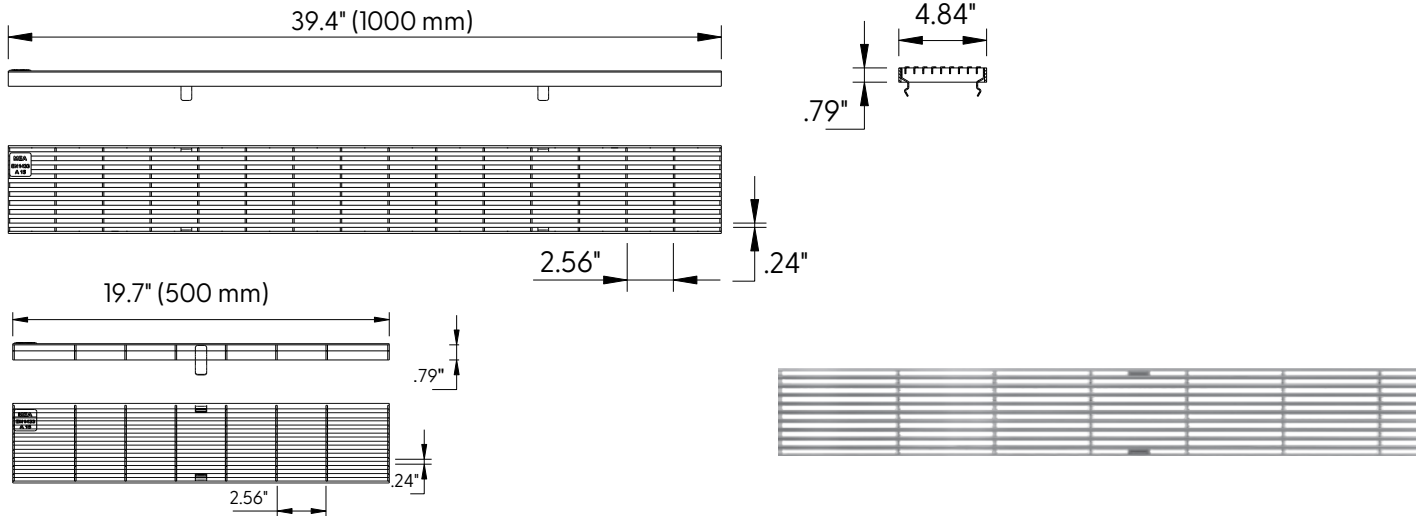

### CLIPFIX ADVANTAGE

The MEA polymer concrete and GRP channels are designed for our universal CLIPFIX grate locking mechanism. The system (channel and grate) provides longitudinal shift protection.

LOAD CLASS B



EN 1433 - 28,100 LBS.,  
125kN, 580 PSI

Compliance



ADA



HEELPROOF

GRATE MODEL NUMBER	LENGTH
T100-PGB-13-LS	39.4" (1000 mm)
T100-PGB-13-LS-500	19.7" (500 mm)

Job Name: _____	Page No: _____
Section No: _____	Contractor: _____
Schedule No: _____	Purchase Order No: _____

Revision Date: 07/13/2022

CALIFORNIA PROPOSITION 65 WARNING. This product contains chemicals known to the State of California to cause cancer and birth defects or other reproductive harm.

MIFAB reserves the right to make changes in material and design without formal notice and obligation. USA: 1-800-465-2736 www.mifab.com CAN: 1-800-387-3880