

Location: _____



R1200-SO

LARGE SUMP DUAL OUTLET ROOF DRAIN

Specification: MIFAB® Series R1200-SO lacquered fabricated deep sump roof drain with No Hub side and bottom outlet, 15" diameter anchor flange, large cast iron waterproofing membrane clamp ring with integral gravel stop, and standard selflocking low profile aluminum dome strainer.

Function: Used in any type of flat roofs. Large free area dome provides for efficient drainage of rainwater and prevents debris from entering the drain line. Extra wide anchor flange and membrane clamp with tongue in groove design provides for secure grip of membrane and roof flashing materials.

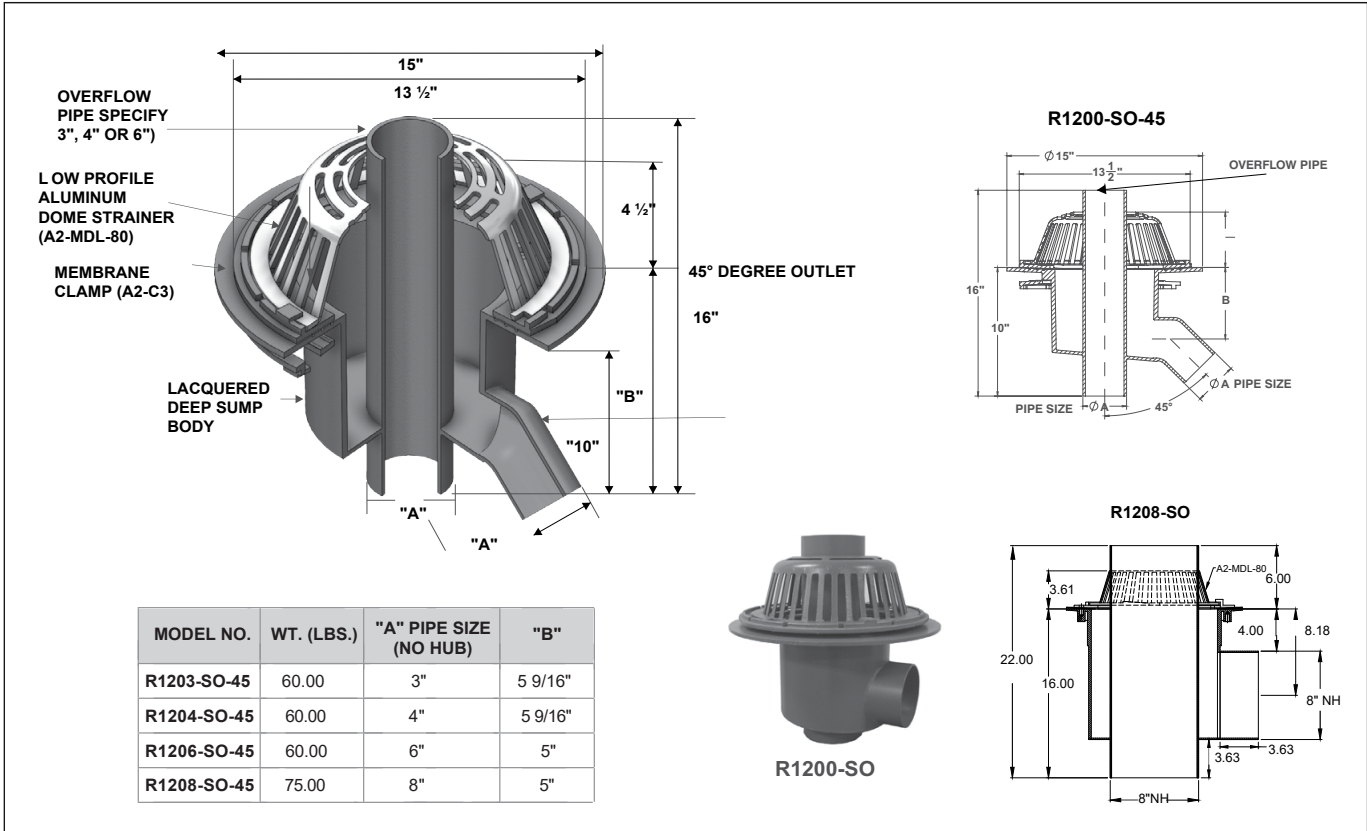

SUFFIX	OPTIONAL VARIATIONS
-6	Vandal proof dome
-11	Acid resistant epoxy coating
-12	Galvanized metal dome
-12A	Galvanized body and membrane clamp
-12B	Galvanized metal dome and membrane clamp
-13	Galvanized body, membrane clamp and dome
-45	45 Degree sewer line connection outlet
-81	Rough bronze dome
-83	Stainless steel mesh screen over metal dome
-B	Sump receiver
-BA	Minimum 51% material cost made in the USA
-DU	Fabricated, powder epoxy coated steel dome on overflow pipe 3", 4"

SUFFIX	OPTIONAL VARIATIONS
-DU6	Fabricated, powder epoxy coated steel dome on overflow pipe 6"
-G	Stainless steel ballast guard
-M	Metal dome
-MS	Stainless steel mesh screen on overflow pipe
-OP	2" high overflow pipe
-SS	Secondary Strainer (Overflow)
-U	Underdeck clamp
-V	Fixed Static Extension 2", 3", 4"
-VG	Galvanized fixed extension (2", 3", 4")
-W-1	Water proofing flange

CALIFORNIA PROPOSITION 65 WARNING. This product contains chemicals known to the State of California to cause cancer and birth defects or other reproductive harm.

Job Name: _____

Page No: _____

Section No: _____

Contractor: _____

Schedule No: _____

Purchase Order No: _____