

Location: _____



R1200-RB

LARGE SUMP DECK DRAIN WITH ADJUSTABLE EXTENSION & 12" X 12" HEELPROOF, ROTATABLE TOP ASSEMBLY

Specification: MIFAB® Series R1200-RB lacquered cast iron deep sump roof drain with 15" diameter anchor flange, large cast iron waterproofing membrane clamp ring with integral gravel stop, 4" high stainless steel ballast guard with 1/4" perforations, square adjustable collar and standard 12" (305) square hinged ductile iron tractor grate with 1/4" wide heelproof drainage slots and a free area of 51 square inches.

Function: Used in flat roofs and decks designed for promenade or recreational areas. Large square top blends in with tile and brick patterns and has enough free area for efficient drainage of rainwater. 1/4" wide heelproof drainage slots are ideal for promenade areas. Extra wide anchor flange and membrane clamp with tongue in groove design provides for secure grip of membrane and roof flashing materials. This unique design permits one to align the square tile with the square tile or brick pattern.

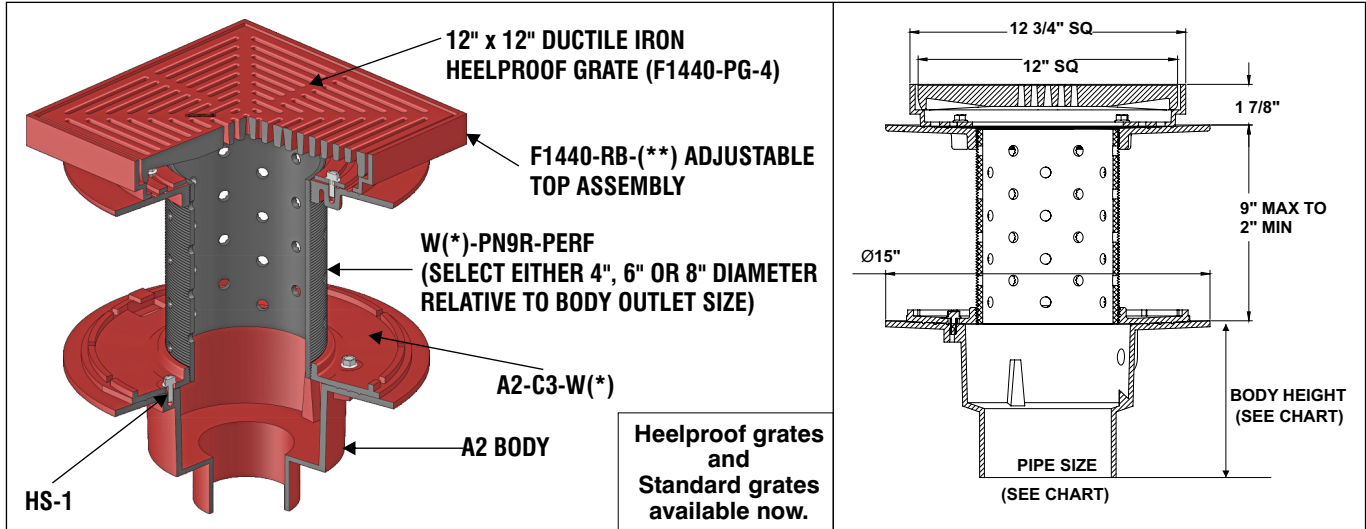

PARTS	F1440-RB-(**)	HS-1	A2 BODY	A2-C3-W(*)	W(*)-PN9R-PERF	A2-ES-(*)

(**) Denotes strainer finish (-1, -3 or -4)

(*) Indicates 4", 6" or 8" Diameter

LACQUERED CAST IRON BODY WITH:		
MODEL NO.	WT Lbs.	OUTLET SIZE
R1202,3,4-RB	52.75	2", 3, 4"
R1205,6-RB	55.00	5", 6"
R1208-RB	57.00	8"

Also available with 12" round top assembly. Add suffix -R.

Suffix	Description
P	Push on outlet , (2",3",4" 6")*
T	Threaded outlet, (2", 3", 4", 5" or 6")
-U	Underdeck clamp (A2-C3) (A368-DC for 8")
-U3	Underdeck clamp with cut away side (A2-C3-C0)
X	Inside caulk outlet (2", 3", 4", 5" or 6")
-Z	Extended wide flange on body (20" Dia .x 1/4 thick)
-5	Cast iron sediment bucket

CALIFORNIA PROPOSITION 65 WARNING. This product contains chemicals known to the State of California to cause cancer and birth defects or other reproductive harm.

Job Name: _____ Page No: _____
 Section No: _____ Contractor: _____
 Schedule No: _____ Purchase Order No: _____