

Location: _____



R1200-JD-W31P24L-F1444

PLANTING AREA DRAIN

Specification: MIFAB® Series R1200-JD-W31P24L-R1444 lacquered cast iron large planting area drain with anchor flange, cast iron water proofing membrane clamp ring, cast iron dome with stainless steel mesh with perforated PVC standpipe with lacquered cast iron large planting area drain with anchor flange and ductile iron grate assembly.

Function: Used to drain water that accumulates on green roof applications. The perforated stainless steel ballast guard prevents vines from entering the drain line.

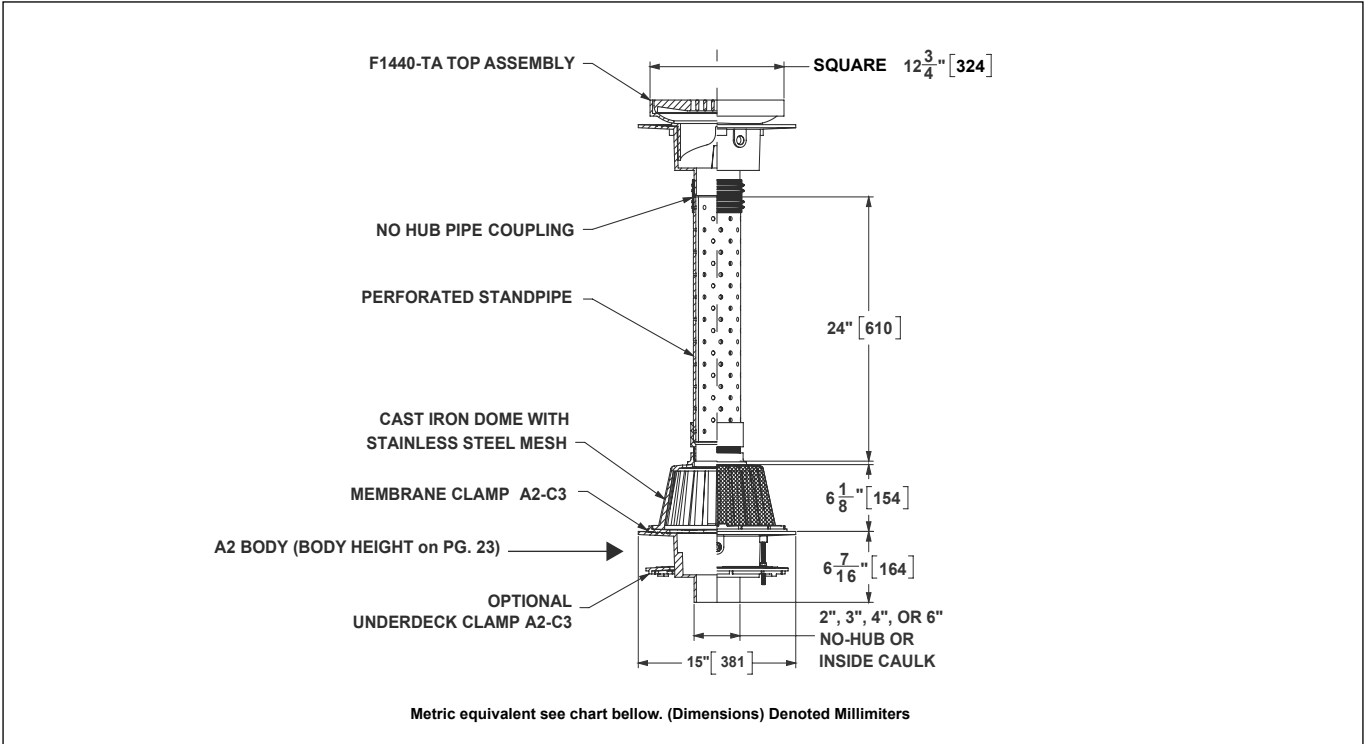

PIPE SIZE	A8 BODY HEIGHT	
	NO HUB (STANDARD)	INSIDE CAULK (X)
2" (51)	4 1/8" (104)	5.05" (127)
3" (76)	4 1/8" (104)	5.05" (127)
4" (102)	4 1/8" (104)	5.05" (127)
5" (127)	4 1/8" (104)	5.05" (127)
6" (152)	4 1/8" (104)	5.05" (127)

Suffix	Description
-1	Nickel bronze veneer
-3	Stainless steel veneer
-3P	Perforated Stainless Steel standpipe (Type 304) - 24"
-6	Vandal proof (Metal dome only) (H-1029)
-11	Acid resistant epoxy coated body, membrane clamp & dome
-12	Galvanized metal dome
-12A	Galvanized body and membrane clamp
-12B	Galvanized metal dome and membrane clamp
-13	Galvanized body, metal dome and membrane clamp
-28	Stainless steel body (Type 304)
-B	Sump receiver (A8-BP)
-BA	Minimum 51% material cost made in the USA

-E	Adjustable extension
-EG	Galvanized Adjustable Extension
-G	Ballast guard (A8-BG)
-PA	Pennsylvania Steel Act compliant product
-P(*)L	(*) indicates total custom length of PVC standpipe required
-U	Underdeck clamp (A8-UDC)
-V	Fixed extension, (2", 3", 4") (A8-V2, A8-V3, A8-V4)
-VG	Galvanized fixed extension, (2", 3", 4")
-W-1	Water proofing flange (A8-W-1)
X	Inside caulk outlet, (2", 3", 4", 5" or 6")
-Z	Extended wide flange on body (20" Dia. x 1/4 thick)

CALIFORNIA PROPOSITION 65 WARNING. This product contains chemicals known to the State of California to cause cancer and birth defects or other reproductive harm.

Job Name: _____ Page No: _____

Section No: _____ Contractor: _____

Schedule No: _____ Purchase Order No: _____