

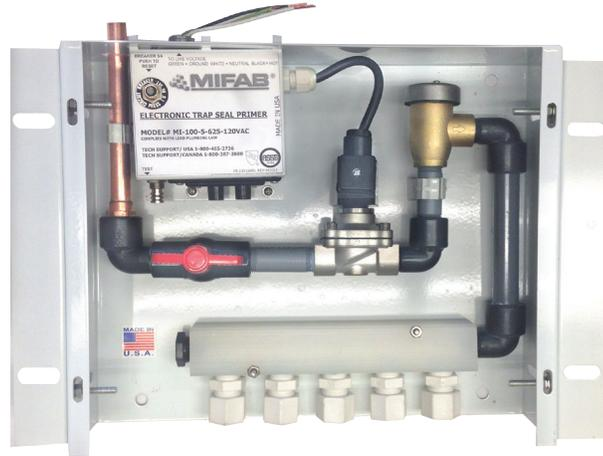

www.mifab.com

TSP-2015

Go to
www.mifab.com
for the most
current product
specification
sheets.



Trap Seal Primers and Water Hammer Arrestors

LIT-062

TSP-2015 - PICTORIAL INDEX

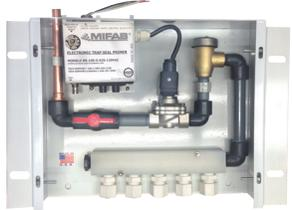
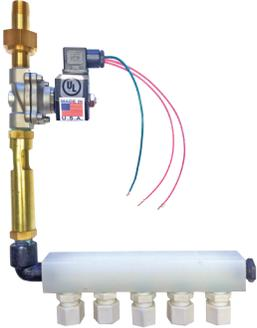
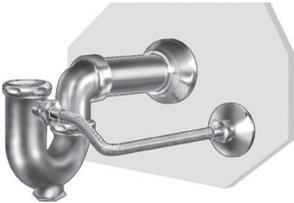
 <p>M-500-NPB (page 4)</p>	 <p>MI-TSP-NPB (page 5)</p>	 <p>MI-DU (page 5)</p>	 <p>MI-100 (page 6)</p>
 <p>MI-200 (page 10)</p>	 <p>MI-300 (page 10)</p>	 <p>MI-300-BP (page 11)</p>	 <p>MI-700 (page 12)</p>
 <p>MI-750 (page 12)</p>	 <p>MI-600-50 (page 13)</p>	 <p>MI-600 (page 13)</p>	 <p>MI-TEMP-NPB (page 13)</p>
 <p>MI-GARD (page 14)</p>	 <p>CL-NPB (page 16)</p>	 <p>WHB (page 17)</p>	 <p>WHS (page 19)</p>

MIFAB TRAP SEAL PRIMER SELECTION GUIDE

Trap seal primers are a necessity where floor drains are infrequently used and in areas such as mechanical and service rooms. In surprisingly little time, evaporation of water in floor drain traps will allow sewer gas to enter the interior of the building. Today's typical method of cleaning floors produces very little water that runs into floor drains. In mechanical rooms, warm dry conditions and air pressure changes caused by HVAC equipment may also serve to compromise the water seal. Trap seal primers provide a supply of water to replenish the deep seal or "P" trap of a drain to prevent sewer or potentially explosive methane gas from entering the area through the floor drains. They are installed on the potable cold water supply line, and react to water flowing in the line to trigger, either by turbulence or pressure drop. Once a triggering event occurs, the primer will release water that is piped to a trap primer connector on or near the "P" trap being maintained. The selection and specification of trap seal primers merits careful consideration. Outlined below are some of the factors to be aware of when planning to use trap seal primers effectively. Installation and local code requirements must be taken into account when specifying trap seal primers. The A.S.S.E. (American Society of Sanitary Engineers) trap seal primer standard #1018 is the key standard that relates to trap seal primers. MIFAB's M-500-NPB and MI-TSP-NPB trap seal primers are tested and certified to the A.S.S.E. 1018 Standard.

MIFAB's trap seal primers have been tested and certified to comply with the low lead plumbing law. These products have been verified with weighted average lead content of less than .25% of the wetted surface.

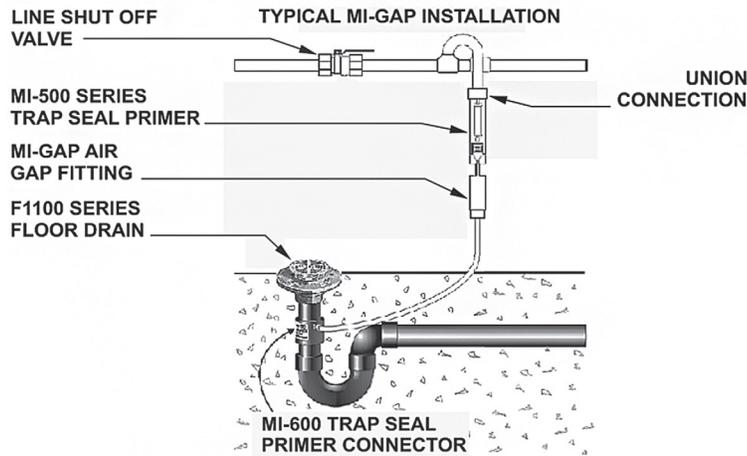

TYPES OF TRAP SEAL PRIMERS

There are four main types of trap seal primers. They include: continuous flow, pressure drop activated, flush valve operated and electronic.

CONTINUOUS FLOW TRAP SEAL PRIMERS

Continuous flow trap seal primers are the original style of trap seal primers. They are typically constructed of cast brass or bronze with a neoprene rubber poppet float on the inside that rises upward as water flows through the primer. When the poppet rises off of its seat, water flows from the primer, through the plumbing line connection, and into the floor drain trap. They are manufactured in either sweat, threaded or union connections and should be installed in a vertical position within the horizontal water supply line, at least ten inches above the floor drain trap that it serves. Continuous flow trap seal primers do not have any method of screening out line debris. This often results in their clogging and either flowing water continuously, or not at all. The volume of water that they discharge is directly related to the amount of water that continuously flows through them. For these reasons, pressure drop activated trap seal primers have become the selection of choice for specifiers.

ELECTRONIC TRAP SEAL PRIMERS

MIFAB's MI-100 Series of electronic trap seal primers are a pre-assembled electronic trap seal primer system programmed to maintain the water seal of floor drain traps. The device is made with an A.S.S.E. approved vacuum breaker, solenoid valve operated by a timer, shut off valve for maintenance and a manifold system to distribute water evenly to the desired floor drain traps. The design is programmed at MIFAB's factory with standard flush times. These flush times can be adjusted by the operator in order to discharge more or less water to the floor drain traps, depending on the installation and climate conditions. Applications include commercial buildings such as schools, hospitals, manufacturing facilities, and any other buildings that require floor drain trap seal protection. The distribution of water from the MI-100 to the traps avoids possible odors coming from the drains.

MIFAB TRAP SEAL PRIMER SELECTION GUIDE (Cont'd)

PRESSURE DROP ACTIVATED TRAP SEAL PRIMERS

Pressure drop activated trap seal primers are typically manufactured out of brass. They are made with a 1/2" M.I.P. inlet connection and a 1/2" F.I.P. outlet connection. They have an interior cartridge that seals when the line pressure is in a static state. When the line pressure drops as little as three p.s.i. (pounds per square inch) (caused by the flushing of a toilet, opening of a faucet, or any draw of water from the water supply line within a close distance to the primer) the interior cartridge will rise due to the pressure differential within the primer and a metered amount of water is discharged under pressure into the plumbing line connected to the floor drain trap. Pressure drop activated trap seal primers are supplied with a fine mesh stainless steel filter that will screen out debris to ensure that the cartridge is not clogged and that the water deliveries are uniform. The filter is easily accessible for quick cleaning or replacement. Three different cartridges offer three different water deliveries into the floor drain, depending on the number of floor drain traps served and the evaporation rate of the water in the floor drain traps. Assuming line pressure of 60 p.s.i., and a line pressure drop of 3 p.s.i., MIFAB's MR-500-NPB trap seal primer will discharge a one half ounce of water, the M1-500-NPB will discharge a full ounce of water and the M2-500-NPB will discharge a one quarter ounce of water into the floor drain trap every time the line pressure changes by 3 p.s.i.

FLUSH VALVE TRAP SEAL PRIMERS

Flush valve trap seal primers are installed below the flush valve and direct an amount of waste water discharged from the flush valve into a tube that connects to the floor drain trap to maintain the water seal. Their advantages are that the water used is already consumed by the flush valve operation, and this type of primer has no moving parts. Their disadvantage is that their location is determined by the location of the fixtures which may be too far away from the floor drains to be practical; unlike supply line mounted trap seal primers which can be more easily installed close to the floor drain trap to be primed. Many installations cannot use flush valve trap seal primers because the floor drain traps are too far away to be reached by the flush valve trap seal primer.



MIFAB TRAP SEAL PRIMER SELECTION GUIDE (Cont'd)

INSTALLATION CONSIDERATIONS

Continuous flow and pressure drop activated trap seal primers should be installed at least 12" above the floor drain traps for every 20 feet of distance to the drain to ensure that there is enough of a slope for the discharged water to flow to the traps. MIFAB recommends pre-priming the traps, as trap seal primers are meant to replace trap water loss through evaporation, etc. Pressure drop activated primers should be connected to the water supply line with a vertical elbow to limit line debris from entering and contaminating the valve. The primer itself should be installed vertically. Access doors should always be specified to provide easy access to all trap seal primers. Trap seal primers have moving parts that will eventually wear or be compromised by line debris even in the best of circumstances. The access doors specified should be large enough to provide "hand access" to the trap seal primer, related accessories and line shut off valve. For quick and easy repair, a line shut off valve and union connections are recommended directly before the trap seal primer on the water supply line. The closing of this valve will facilitate the cleaning and maintenance of the primer without having to separately shut off the building's water supply. Water supply lines should be flushed at least five times before the trap seal primers are initially installed to ensure that debris will not enter the primers and negatively affect their performance. Pipe dope and paste should never be used when installing trap seal primers in water supply lines because the fine residue from these adhesives will enter the trap seal primers and clog the cartridges. Install the trap seal primer as close to the source of the pressure drop as possible. Fixtures with a water restriction device may not cause a large enough pressure drop to activate the trap seal primer.

AIR GAP FITTING

Many local codes require the use of an air gap fitting underneath the trap seal primer (see MIFAB's MI-GAP-NPB product). The purpose of an air gap fitting is to provide a vertical space that is twice the diameter of the water supply connection in order to ensure positive protection against backflow. ANSI / ASME Standard A112.1.2 air gap in plumbing systems is written for the application of air gap fittings. It is recommended that air gaps be specified for use in areas where splashing water from the air gap will not be objectionable or cause damage.

DISTRIBUTION UNITS

Distribution units can be installed underneath pressure drop activated trap seal primers to distribute water to up to ten floor drain traps that are in close proximity to each other. (See MIFAB's MI-DU product) Typically, distribution units are used when a men and women's restroom are located side by side with a common pipe chase between them. In this instance, one trap seal primer with a distribution unit dialed to the 2 setting can be used to service both floor drain traps. This eliminates a second costly installation procedure, shut off valve, access door and air gap fitting. MIFAB's distribution units are engineered so that they

do not need to be installed level to distribute water evenly and can be adjusted to serve either two, three or four floor drain traps with a single unit. Up to ten floor drain traps can be served by having one main distribution unit feed others below it. Contact MIFAB for layout information on distribution units serving multiple drains.

LINE SHUT OFF VALVE

The closing of this valve will facilitate the cleaning and maintenance of the primer without having to separately shut off the building's water supply. Water supply lines should be flushed several times before the trap seal primers are initially installed to ensure that debris will not enter the primers and negatively affect their performance. Pipe dope and paste should never be used when installing trap seal primers in water supply lines because the fine residue from these adhesives will enter the trap seal primers and clog the cartridges. Once installed, pressure drop activated trap seal primers should be cycled at least five times to ensure reliable operation. Quickly opening and closing the line shut off valve can accomplish this. Four view holes located directly across from each other at the bottom of the pressure drop activated trap seal primers allow easy observation of water discharging into the make up line that leads to the floor drain trap.

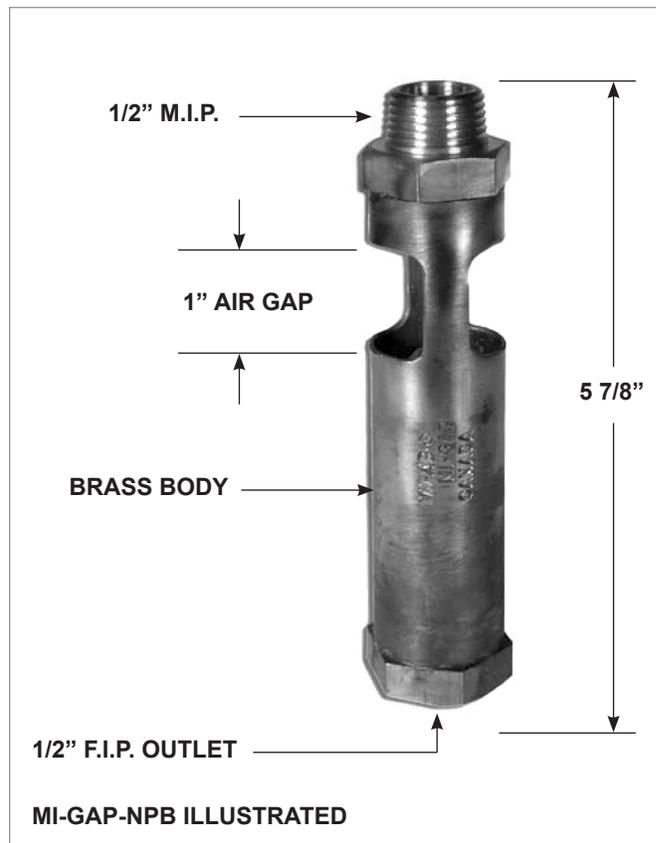

M-500-NPB PRESSURE DROP ACTIVATED TRAP SEAL PRIMER

3 P.S.I PRESSURE DROP
 Only a three p.s.i. line pressure drop is required to activate the primer, compared to five or ten p.s.i. by others. Lower water volume fixtures and faucets has resulted in lower line pressure drops. A three p.s.i. performance point ensures reliable water delivery to maintain the trap seal.

NO PRECHARGE
 MIFAB's trap seal primers can be disassembled in the field for easy cleaning and repair, without risk of losing a precharge.

VIEW HOLES
 Four view holes permit easy inspection of water delivery. The holes are across from each other, enabling light at the opposite end to illuminate the performance of the primer.

Note: See pages 20 and 21 for CSA and IAPMO approval certificates.

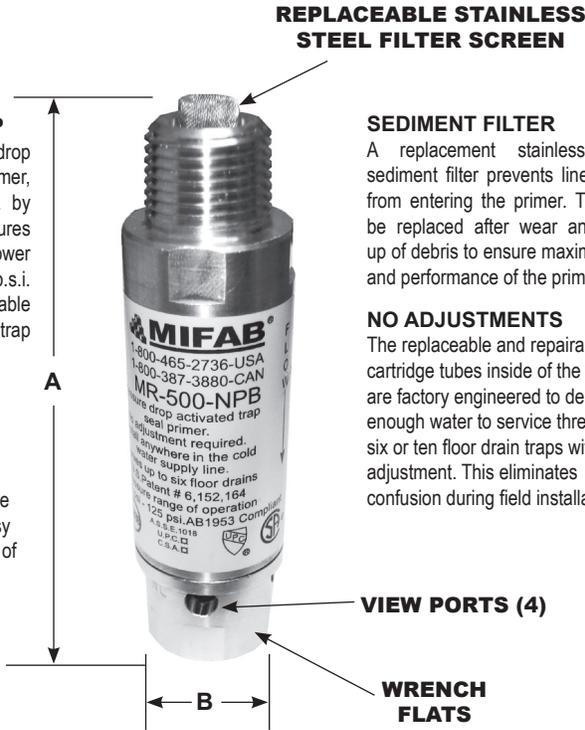

REPLACEABLE STAINLESS STEEL FILTER SCREEN
SEDIMENT FILTER
 A replacement stainless steel sediment filter prevents line debris from entering the primer. This can be replaced after wear and build up of debris to ensure maximum life and performance of the primer.

NO ADJUSTMENTS
 The replaceable and repairable cartridge tubes inside of the body are factory engineered to deliver enough water to service three, six or ten floor drain traps without adjustment. This eliminates confusion during field installation.

MIFAB MR-500-NPB, M1-500-NPB & M2-500-NPB SERIES pressure drop activated brass trap seal primer, with inlet opening of 1/2" M.I.P. and outlet opening of 1/2" F.I.P. Complete with four view holes and removable stainless steel filter screen. Requires no adjustments and no air pre-charge. MIFAB'S Series of pressure activated trap seal primers (MR-500-NPB, M1-500-NPB and M2-500-NPB) can be connected to any cold water line, and will activate when a valve or faucet is opened, resulting in at least a 3 p.s.i. pressure drop. **A pressure drop of three p.s.i. will activate all of the trap seal primers.** MIFAB's Series of trap seal primers can be disassembled in the field. Their unique design permits filter replacement without affecting the performance of the primer. The "O" ring seals are tested for reliability at a temperature range of -40 degrees to 450 degrees F. The M-500 Series of trap seal primers do not require adjustment. The operating range for all of MIFAB's Series of trap seal primers is 20 - 80 p.s.i.

All three models are listed with I.A.P.M.O. and C.S.A. (File #110892_0_000) and are tested and certified to the A.S.S.E. Standard 1018 and are so marked. U.S. Patent # 6,152,164



M-500 SERIES						
MODEL	LIST PRICE	A	B	PIPE FLATS	DRAINS SERVED	WATER OUTPUT
MR-500-NPB	\$75.00	4-1/8"	1-1/4"	1-1/8"	6	1/2 oz.
M1-500-NPB	\$80.00	4-1/8"	1-1/4"	1-1/8"	10	1 oz.
M2-500-NPB	\$77.50	4-1/8"	1-1/4"	1-1/8"	3	1/4 oz.

M-500 OPTIONAL VARIATIONS							
MODEL NUMBER	DESCRIPTION	SHIP WEIGHT	CARTON QTY.	CARTON WEIGHT	LEAD FREE MATERIAL (-NPB)	REPLACEMENT FILTER SCREEN (-RF)	REPLACEMENT CARTRIDGE (-RC)
MR-500-NPB	Up to 6 drains	.75 lbs.	25	18.35 lbs.	No Add	\$37.00	\$47.25 (green cartridge)
M1-500-NPB	Up to 10 drains	.75 lbs.	25	18.35 lbs.	No Add	\$37.00	\$53.50 (black cartridge)
M2-500-NPB	Up to 3 drains	.75 lbs.	25	18.35 lbs.	No Add	\$37.00	\$50.50 (red cartridge)
M-500-UN						\$37.00	\$53.50

Note: See page 24 for installation, operation and maintenance instructions.



M-500-UN For optional Union Connection use suffix (-UN). Read description below.

The union connection (Model # M-500-UN) permits easy access to the top of the trap seal primer for cleaning and maintenance. Simply solder the pipe to the top of the union nut. Screw the union nut onto the top of the MR-500-NPB, M1-500-NPB or M2-500-NPB trap seal primer during installation. When cleaning or maintenance of the trap seal primer is required, one can easily unscrew the union nut to access the trap seal primer and not have to cut the water supply pipe to access the trap seal primer.

MI-TSP-NPB CONTINUOUS FLOW TRAP SEAL PRIMER



MI-TSP-1-NPB
1/2" SWEAT CONNECTION



MI-TSP-2-NPB
(NPT) THREADED



MI-TSP-3-NPB
THREADED WITH
UNION CONNECTIONS

Note: See pages 20 and 21 for CSA and IAPMO approval certificates.



T01 UNION CONNECTION

MODEL NO.	DESCRIPTION	LIST PRICE	ADD FOR: CHROME PLATED (-CP)	SHIP WEIGHT (Lbs.)	CARTON QTY.	WEIGHT (Lbs.)	REPAIR KIT (-RK)
MI-TSP-1-NPB	1/2" Sweat	SEE MPB PRICE BOOK	SEE MPB PRICE BOOK	1.0	20	20	SEE MPB PRICE BOOK
MI-TSP-2-NPB	1/2" Threaded	SEE MPB PRICE BOOK	SEE MPB PRICE BOOK	1.0	20	20	SEE MPB PRICE BOOK
MI-TSP-3-NPB	1/2" Threaded with union connections	SEE MPB PRICE BOOK	SEE MPB PRICE BOOK	1.0	20	20	SEE MPB PRICE BOOK

Part number for MI-TSP-1,2,3-NPB, repair kit is MI-TSP-RK. (SUFFIX - RK)

MI-DU TRAP SEAL PRIMER DISTRIBUTION UNIT

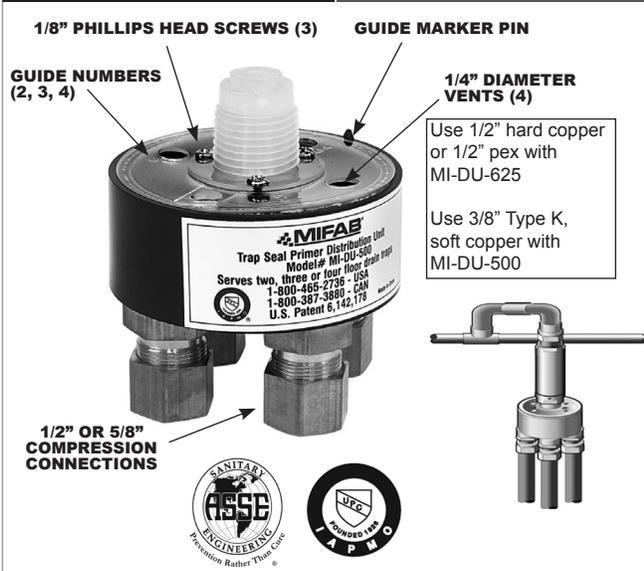

MIFAB's MI-DU trap seal primer distribution unit is engineered to receive a metered amount of water from a trap seal primer and distribute the water equally to either two, three or four floor drain traps. Choose from either 1/2" or 5/8" compression connections by indicating suffix (-500) for 1/2" or suffix (-625) for 5/8". The lid of the distribution unit has the numbers "2", "3" and "4" marked on it. The body of the distribution unit has a guide marker on the top of the body. The numbers and the guide marker are positioned by removing the three screws in the lid of the unit and rotating the lid to match the appropriate numbers with the guide marker to provide priming for the desired number of drains. Do not over torque the three lid screws when securing the lid back to the body. It is not necessary to install MIFAB's distribution perfectly level. The unique design will distribute water uniformly when out of level up to 5 degrees.

Model MI-DU is listed with I.A.P.M.O.
U.S. Patent #6,142,178.

MODEL NO.	DESCRIPTION	LIST PRICE -500 (1/2" compression)	LIST PRICE -625 (5/8" compression)	SHIPPING WEIGHT	CARTON QTY.	CARTON WT.
MI-DU	Trap Seal Primer Distribution unit that serves two, three or four floor drain traps.	\$40.00 (for 3/8" copper)	\$40.00 (for 1/2" copper)	.75 lbs.	6	4.5 lbs.

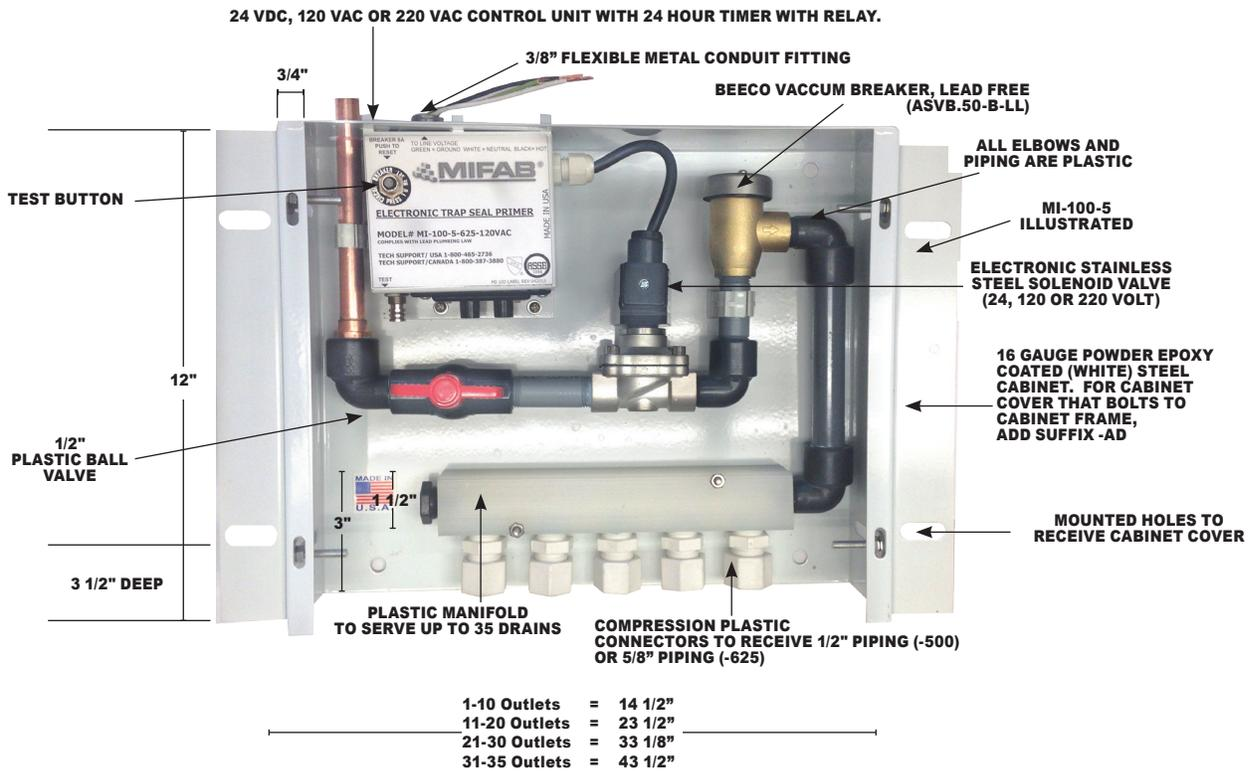
MI-100
ENCLOSED ELECTRONIC TRAP SEAL PRIMER

The MI-100 is engineered for equal distribution of water to all ports. It's the perfect solution to keep sewer gas from entering the building from seldom used floor drains. The MI-100 can be located anywhere in the water supply and is engineered to permit the building owner to adjust the frequency and amount of water delivery through a timer and stainless steel solenoid valve. A manifold ensures that a minimum of 2 ounces of water are delivered to every port over a twenty-four hour period. The unit must be mounted 12" above the finished floor for every 20' of water supply line. The MI-100 can be installed with a cabinet cover. The system is capable of priming from 1 to 35 floor drain traps. The MI-100 is practical to serve many floor drain traps in infrequently used buildings such as convention centers and sports facilities. The MI-100 is made of lead free materials that touch water.

***NOTE: Cabinet can be surface or flush mounted. The same cabinet can be installed either way.**

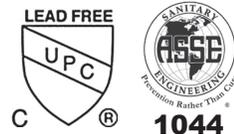

Note: See pages 8 and 9 for installation, operation and maintenance instructions.

Note: See pages 18 and 19 for ASSE and IAPMO approval certificates.

MI-100

MODEL NO.	DESCRIPTION	LIST PRICE	SHIPPING WT.
MI-100-5	1-5 opening ports with cabinet*	\$1,529.00	25 lbs.
MI-100-10	6-10 opening ports with cabinet*	\$1,581.00	26 lbs.
MI-100-15	11-15 opening ports with cabinet*	\$1,607.00	27 lbs.
MI-100-20	16-20 opening ports with cabinet*	\$1,886.00	28 lbs.
MI-100-25	21-25 opening ports with cabinet*	\$1,932.00	35 lbs.
MI-100-30	26-30 opening ports with cabinet*	\$1,983.00	36 lbs.
MI-100-35	31-35 opening ports with cabinet*	\$2,138.00	37 lbs.

See page 7 for a complete list of the MI-100 Optional Variations.

MI-100, MI-200, MI-300 OPTIONAL VARIATIONS

SUFFIX	DESCRIPTION	MI-100 LIST PRICE	MI-200 LIST PRICE	MI-300 LIST PRICE	MI-300-BP LIST PRICE
-A	Allen key lock for access door (door is separate)	\$19.00	\$19.00	\$19.00	\$19.00
-AD	Cabinet Cover (bolted to cabinet frame and non hinged) (16 gauge powder epoxy coated steel (white))	1-10 Outlets - \$150.00 11-20 Outlets - \$200.00 21-30 Outlets - \$250.00 31-35 Outlets - \$300.00	\$140.00	\$150.00	\$150.00
-ADSS	Stainless Steel (Type 304) Cabinet Cover (bolted to cabinet frame and non hinged) (16 gauge fabricated stainless steel (Type 304))	1-10 Outlets - \$250.00 11-20 Outlets - \$300.00 21-30 Outlets - \$350.00 31-35 Outlets - \$400.00	\$240.00	\$250.00	\$250.00
-BA	Buy American Act compliant product	P.O.A.	P.O.A.	P.O.A.	P.O.A.
-BP	Battery Pack	N/A	No Add	No Add	Included
-C	Cylinder key lock for access door (door is separate)	\$25.00	\$25.00	\$25.00	\$25.00
-DW	Drywall bead frame for access door (5" cabinet depth) (door is separate)	P.O.A.	P.O.A.	P.O.A.	P.O.A.
-ENC	Steel Cabinet to enclose MI-200 / MI-300 (16 gauge powder epoxy coated steel (white) cabinet)	N/A	\$200.00	\$250.00	\$250.00
-ENCSS	Stainless Steel (Type 304) Cabinet to enclose MI-200 / MI-300 (16 gauge fabricated stainless steel (Type 304))	N/A	\$350.00	\$400.00	\$400.00
-MFRU	Uninsulated fire rated access door, flush mount (6" cabinet depth)	(See AD-2012 List Prices)	(See AD-2012 List Prices)	(See AD-2012 List Prices)	(See Access Door Price Book for List Prices)
-PL	Paddle latch for access door (door is separate)	\$62.50	\$62.50	\$62.50	\$62.50
-SS	Stainless Steel (Type 304) Cabinet (16 gauge fabricated stainless steel (Type 304)) <i>(MI-100 only)</i>	1-10 Outlets - \$500.00 11-20 Outlets - \$575.00 21-30 Outlets - \$675.00 31-35 Outlets - \$775.00	N/A	N/A	N/A
-UA	Access door, prime coated (5" cabinet depth)	(See AD-2012 List Prices)	(See AD-2012 List Prices)	(See AD-2012 List Prices)	(See Access Door Price Book for List Prices)
-UASS	Access door, stainless steel (5" cabinet depth)	(See AD-2012 List Prices)	(See AD-2012 List Prices)	(See AD-2012 List Prices)	(See Access Door Price Book for List Prices)
-2M	Brass Manifold with brass compression connections	1-10 Outlets - \$250.00 11-20 Outlets - \$300.00 21-30 Outlets - \$350.00 31-35 Outlets - \$400.00	1-5 Outlets - \$250.00	1-5 Outlets - \$250.00	1 - 5 Outlets - \$250.00
-24VDC	24 VDC	No Add	No Add	No Add	No Add
-75WS	3/4" water supply connection	\$75.00	\$75.00	\$75.00	\$75.00
-120VAC	120 VAC	No Add	No Add	No Add	No Add
-220VAC	220 VAC	No Add	No Add	No Add	No Add
-500	1/2" compression connection ports	No Add	No Add	No Add	No Add
-625	5/8" compression connection ports	No Add	No Add	No Add	No Add

MI-100-10 illustrated

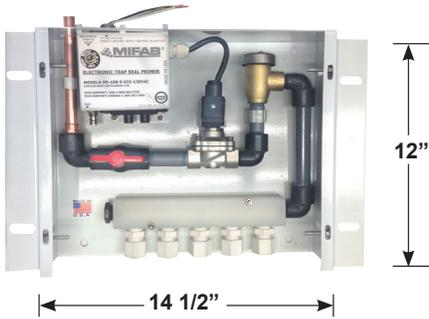

MI-100-20 illustrated

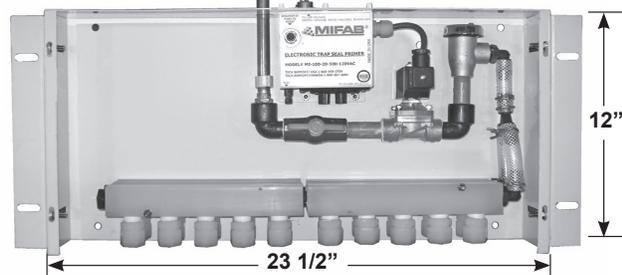

MI-100-30 illustrated

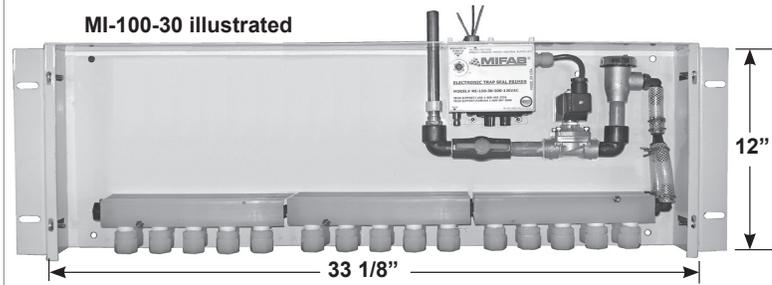

Design and dimensions are subject to modification. Prices do not include applicable taxes.

Visit www.mifab.com for the most recent product information.

MIFAB, Inc., 1321 West 119th Street, Chicago, Illinois 60643-5109, USA

Toll Free: 1-800-465-2736, Fax: 1-773-341-3049

All sales subject to MIFAB's Terms and Warranties. Please refer to page 26.

www.mifab.com • sales@mifab.com • Canada Toll Free: 1-800-387-3880

MI-100 Electronic Trap Seal Primer Installation Instructions

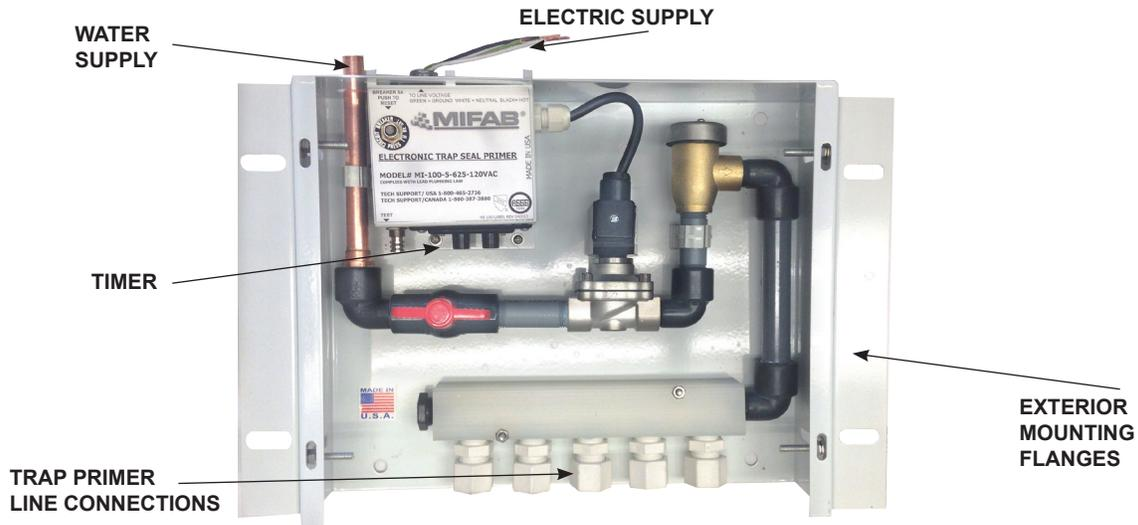

DESCRIPTION: The MI-100 is a pre-assembled electronic trap seal primer programmed to maintain the water seal of up to 35 floor drain traps. It is factory programmed to operate at pre-set flush time intervals and can be modified relative to the site condition or custom requirements. The MI-100 is manufactured with a BEECO vacuum breaker, is easy to install and is maintenance free. Typical installations are schools, hospitals, laboratories, stadiums, bathrooms, manufacturing facilities and food processing facilities. The MI-100 meets LEED credit 3.2 and 5.2 for water reduction and regional material usage.

APPROVALS: The MI-100 Series is tested and certified to the ASSE 1044 electronic trap seal primer Standard and listed with I.A.P.M.O. MIFAB can manufacture it with either 24 VDC, 120 VAC or 220 VAC electrical connections.

INSTALLATION GUIDELINES:

- 1) Properly mount the MI-100 to the wall with # 14 wood or metal screws. It must be level and square. The MI-100 should be secured between wall studs or on the finished wall as close as possible to the drains being serviced.
- 2) The MI-100 is supplied with exterior mounting flanges for flush to the wall installations. For surface mount installations, remove the exterior mounting flanges and use the holes in the back of the cabinet to secure it to the wall.
- 3) The MI-100 must be installed a minimum of 12" above the highest drain being served. Note that the MI-100 should not be considered a pressure feed trap priming system. The manifold within the MI-100 must always be installed so that it is higher than the floor drain traps that it serves. The supply lines from the manifold to the floor drain traps should always be sloped to ensure proper water flow from the manifold to the floor drain traps. The MI-100 can be installed up to 100 feet away from the drains they serve as long as the MI-100 is installed high enough so that there is enough slope from the MI-100 to the drains to ensure water flow.
- 4) Properly connect the electric and water supply lines by following local codes and guidelines. The water supply should be connected to the ½" copper tube located on the top of the MI-100. Connect the trap primer supply lines to the manifold in the MI-100. The black wire is "hot", the white wire is "neutral" and the green wire is "ground". Note that the MI-100-24VDC model is always supplied with a 24 volt converter plug that plugs directly into a 120 volt wall outlet.

MI-100 Electronic Trap Seal Primer Installation Instructions

- 5) Connect either 3/8" (3/8" I.D., 1/2" O.D. tube) or 1/2" (1/2" I.D., 5/8" O.D. pipe) water supply lines to the manifold connections (depending on whether the -500 (3/8") or -625 (1/2") manifold connections are chosen. Any unused connection ports of the manifold should be capped off. To do this, remove the entire compression connection from the underside of the manifold and then thread a 1/2" M.I.P. plug into the female threaded opening in the manifold.
- 6) Ensure that the water supply (with a minimum of 20 psig) is connected and then turn on power to the device. Ensure that the ball valve is open. The MI-100 will then cycle for a half second. Press the Test Button to repeatedly prime the unit. The Test Button may need to be pressed multiple times in order to have water reach all of the drains. Observe for any leaks within the MI-100 piping system. Ensure that all lines are free of debris.

TIMER ADJUSTMENT:

The pre-set timer operates a normally closed stainless steel solenoid valve. The timer consists of two adjustments. The "ON" time - this is the amount of time in between flow cycles and is adjustable from 1 to 8 hours. The "OFF" time - this is the amount of time that the unit is flowing water to the traps - and is adjustable from 1/2 to 2 seconds. The MI-100-5 and MI-100-10 models are factory set to turn the stainless steel solenoid valve "ON" every eight hours for a one half second. The MI-100-15 and MI-100-20 models are factory set to turn the stainless steel solenoid valve on every eight hours for one second and the MI-100-25, MI-100-30 and MI-100-35 models are factory set to turn the stainless steel solenoid valve on every eight hours for two seconds. MIFAB estimates that when the line pressure is 40 p.s.i., 12 ounces of water will flow from the MI-100 manifold system for every half second that the stainless steel solenoid valve is on. Note that cold climate installations (meat lockers and cold storage areas) have an increased rate of evaporation than temperate areas and will therefore need more water flow to the floor drain traps to maintain the water seal. These settings can be adjusted relative to the amount of water evaporation in the floor drain traps to ensure that there is a constant water seal in the floor drain traps.

CAUTION: When using the MI-100 electronic trap seal primer, basic precautions should always be followed:

- 1) Read all of the instructions before installing the MI-100.
- 2) Do not contact moving parts.
- 3) Only use the parts recommended or sold by MIFAB.
- 4) Do not use outdoors.
- 5) To disconnect, remove the plug from the outlet. Do not unplug by pulling on the cord. To unplug, grasp the plug, not the cord. Unplug from the outlet when not in use and before servicing or cleaning the MI-100. Do not install or operate the MI-100 with a damaged cord or plug; or after the MI-100 malfunctions or is dropped or damaged in any way. If you are experiencing issues, contact your local MIFAB representative.
- 6) For hard wired connections, disconnect the power when the MI-100 is not in use and before servicing or cleaning.
- 7) The MI-100 must be connected to a grounded metal, permanent wiring system; or an equipment grounding conductor must be run with the circuit conductors and be connected to the equipment grounding terminal or lead on the MI-100.

MI-200

ELECTRONIC TRAP SEAL PRIMERS WITH AIR GAP

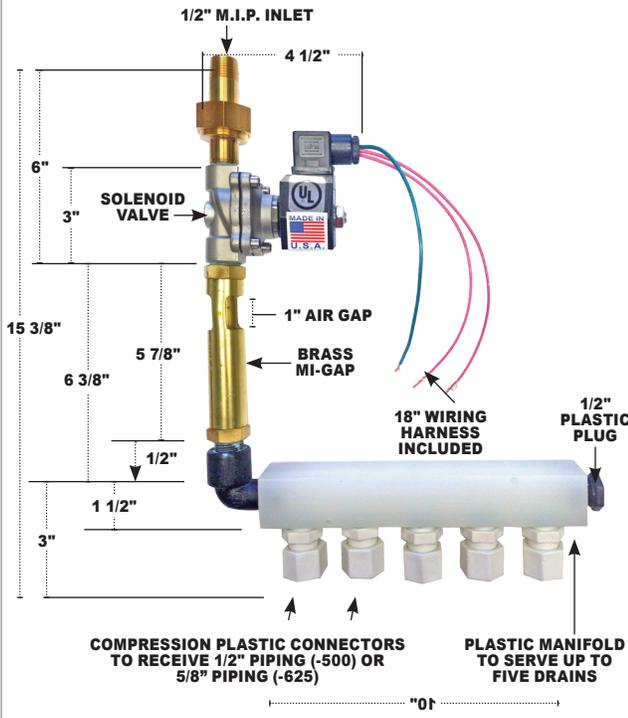

The MI-200 is engineered to connect to the voltage building energy management system used to manage the services in commercial, educational and institutional buildings. It can be located anywhere in the water supply. A manifold is provided as part of the assembly so that up to 5 drains can be served. The MI-200 is practical for infrequently used buildings such as convention centers and sports facilities. The MI-200 is manufactured in accordance with ANSI/ASME A112.1.2 air gap in plumbing systems Standard. UA1818 access door is suggested for access to the MI-200 when installed into the wall.

NOTE: Timer not included.

MI-200			
MODEL NO.	DESCRIPTION	LIST PRICE	SHIPPING WT.
MI-200-24-VDC	24 VDC	\$389.00	2 lbs.
MI-200-120-VAC	120 VAC	\$389.00	2 lbs.
MI-200-220-VAC	220 VAC	\$389.00	2 lbs.

The three models listed in the chart above are without the manifold. To order the manifold please add suffix -500 for 1/2" piping or -625 for 5/8" piping.



See page 7 for a complete list of the MI-200 Optional Variations.

MI-300

ELECTRONIC TRAP SEAL PRIMER WITH AIR GAP, DISTRIBUTION UNIT AND CONTROL PANEL

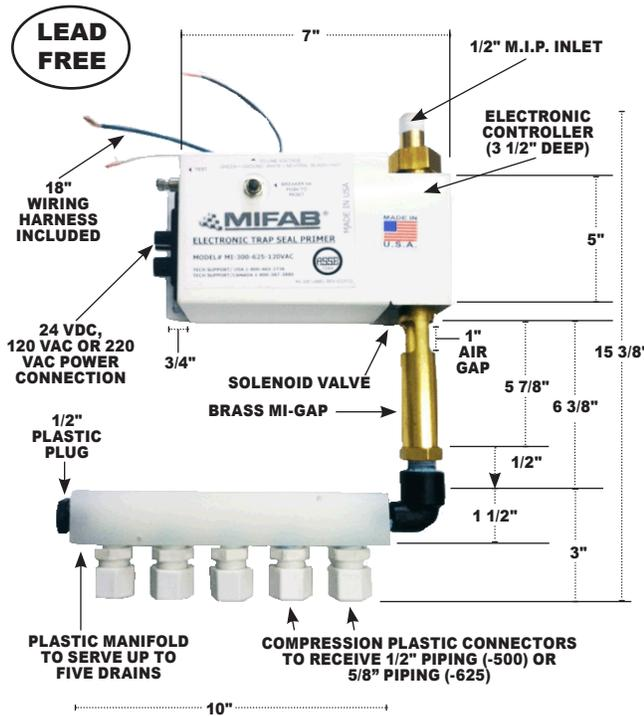

The MI-300 is manufactured with a stainless steel solenoid valve, air gap manifold and electronic controller. The water discharge frequency can be adjusted to meet the building's needs. The MI-300 can be located anywhere in the water supply. A manifold is connected to the bottom of the MI-300 to serve up to 5 drains. The MI-300 is practical for infrequently used buildings such as convention centers and sports facilities. The MI-300 is manufactured in accordance with ANSI/ASME A112.1.2 air gap in plumbing systems Standard. UA 18x18 access door is suggested for access to the MI-300 when installed in the wall.

MI-300			
MODEL NO.	DESCRIPTION	LIST PRICE	SHIPPING WT.
MI-300-24-VDC	24 VDC	\$842.50	4 lbs.
MI-300-120-VAC	120 VAC	\$842.50	4 lbs.
MI-300-220-VAC	220 VAC	\$842.50	4 lbs.

The three models listed in the chart above are without the manifold. To order the manifold please add suffix -500 for 1/2" piping or -625 for 5/8" piping.

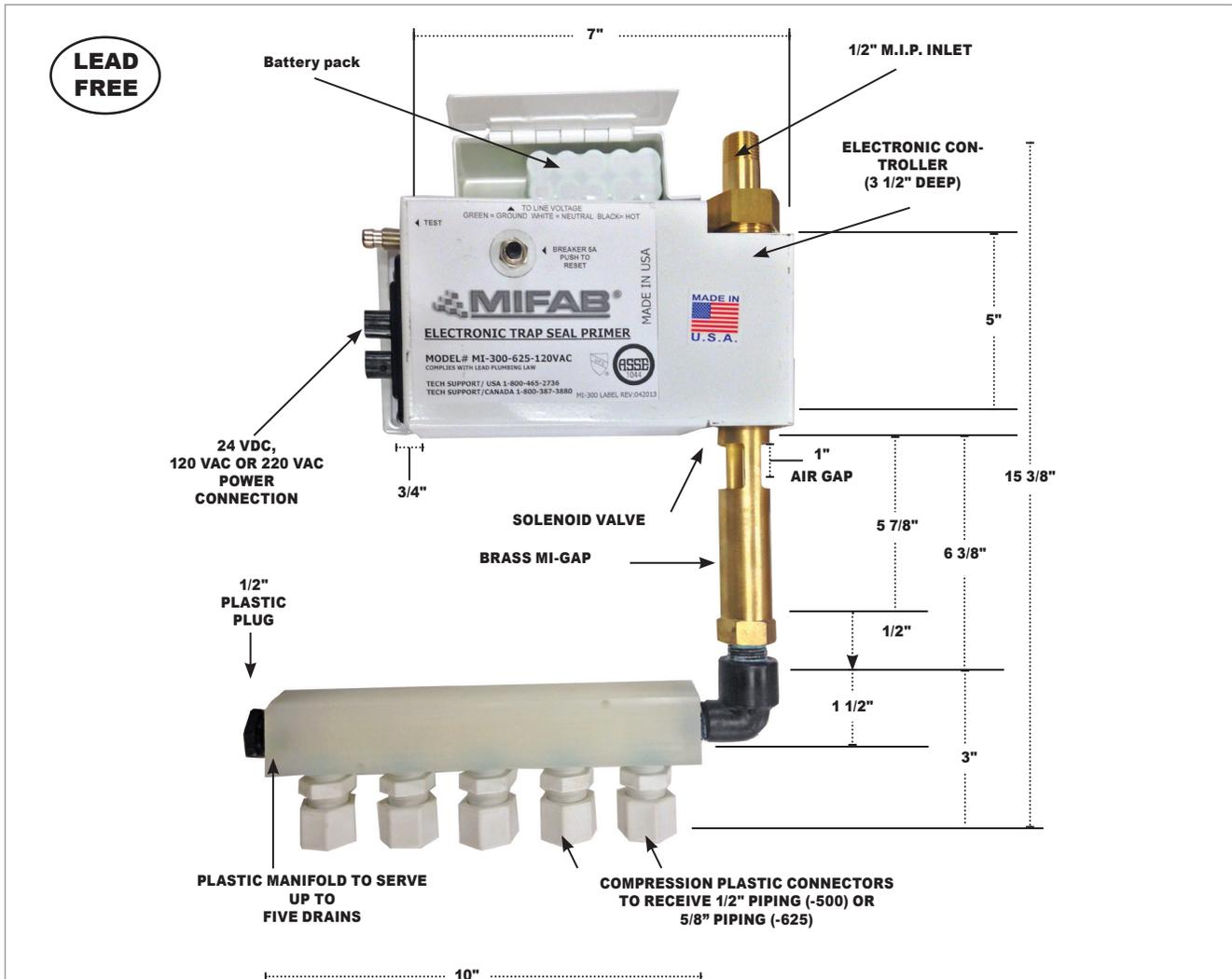

See page 7 for a complete list of the MI-300 Optional Variations.
(such as box enclosures)

MI-300-BP
ELECTRONIC TRAP SEAL PRIMER WITH AIR GAP, DISTRIBUTION UNIT AND CONTROL PANEL POWERED BY A BATTERY PACK

MI-300			
MODEL NO.	DESCRIPTION	LIST PRICE	SHIPPING WT.
MI-300-BP-24-VDC	24 VDC	\$842.50	4 lbs.
MI-300-BP-120-VAC	120 VAC	\$842.50	4 lbs.
MI-300-BP-220-VAC	220 VAC	\$842.50	4 lbs.

The three models listed in the chart above are without the manifold. To order the manifold please add suffix -500 for 1/2" piping or -625 for 5/8" piping.

The MI-300-BP is manufactured with a stainless steel solenoid valve, air gap manifold and battery pack controller. The water discharge frequency can be adjusted to meet the building's needs. The MI-300-BP can be located anywhere in the water supply. A manifold is connected to the bottom of the MI-300-BP to serve up to 5 drains. The MI-300-BP is practical for infrequently used buildings such as those that do not have access to power. The MI-300-BP is manufactured in accordance with ANSI/ASME A112.1.2 air gap in plumbing systems Standard. UA 18x18 access door is suggested for access to the MI-300-BP when installed in the wall.

**See page 7 for a complete list of the MI-300-BP Optional Variations.
(such as box enclosures)**



MI-700 GRAVITY FED TRAP SEAL PRIMERS

MIFAB's MI-700 Series trap seal primers are engineered to prime one floor drain trap that is no further than twenty feet from the fixture. A 1/2" (13) O.D. copper make-up water line connecting the trap seal primer to the floor drain trap is recommended for the M-700 & MI-701.

Note: S.S. braided supply pipe w/escutcheon is available for the MI-702 (option -BH).

List price is **\$43.50** for the -BH option.

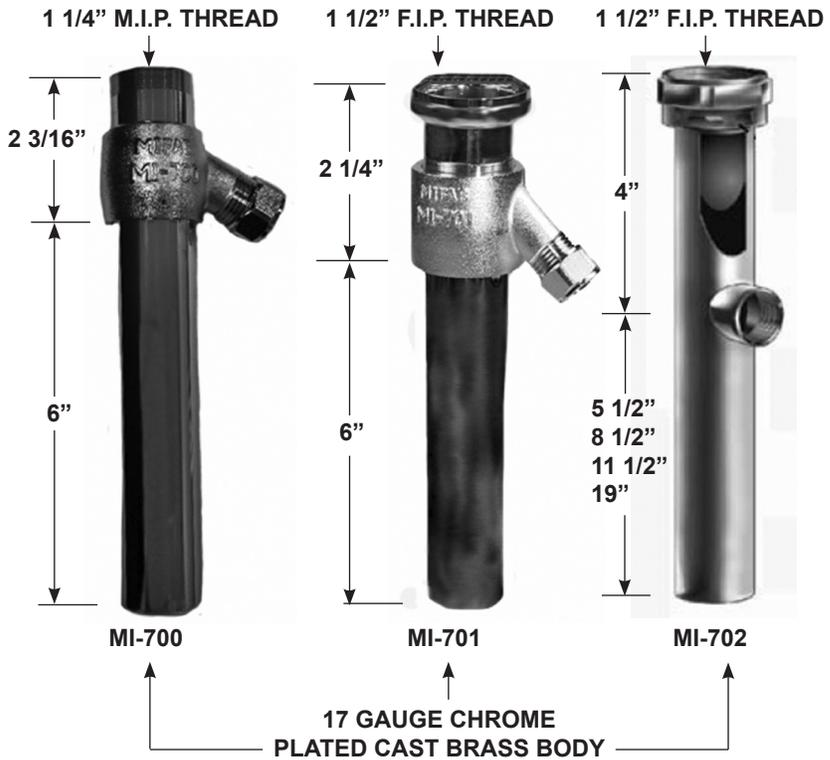

MODEL NO.	DESCRIPTION	LIST PRICE	SHIP WEIGHT (Lbs.)	CARTON QTY.	CARTON WEIGHT (Lbs.)
MI-700	1 1/4" Lavatory Trap Seal Primer	\$58.00	0.75	20	15.00
MI-701	1 1/2" Valve Trap Seal Primer	\$73.50	1.25	20	25.00
MI-702-9.5	1 1/2" Valve Trap Seal Primer w/ VB, 9 1/2" Long	\$75.00	1.25	20	25.00
MI-702-12.5	1 1/2" Valve Trap Seal Primer w/ VB, 12 1/2" Long	\$78.00	1.50	20	30.00
MI-702-15.5	1 1/2" Valve Trap Seal Primer w/ VB, 15 1/2" Long	\$80.00	1.75	20	35.00
MI-702-23	1 1/2" Valve Trap Seal Primer w/ VB, 23 1/2" Long	\$82.50	2.25	20	45.00

MI-750 TAILPIECE TRAP SEAL PRIMER WITH BRAIDED CONNECTING HOSE

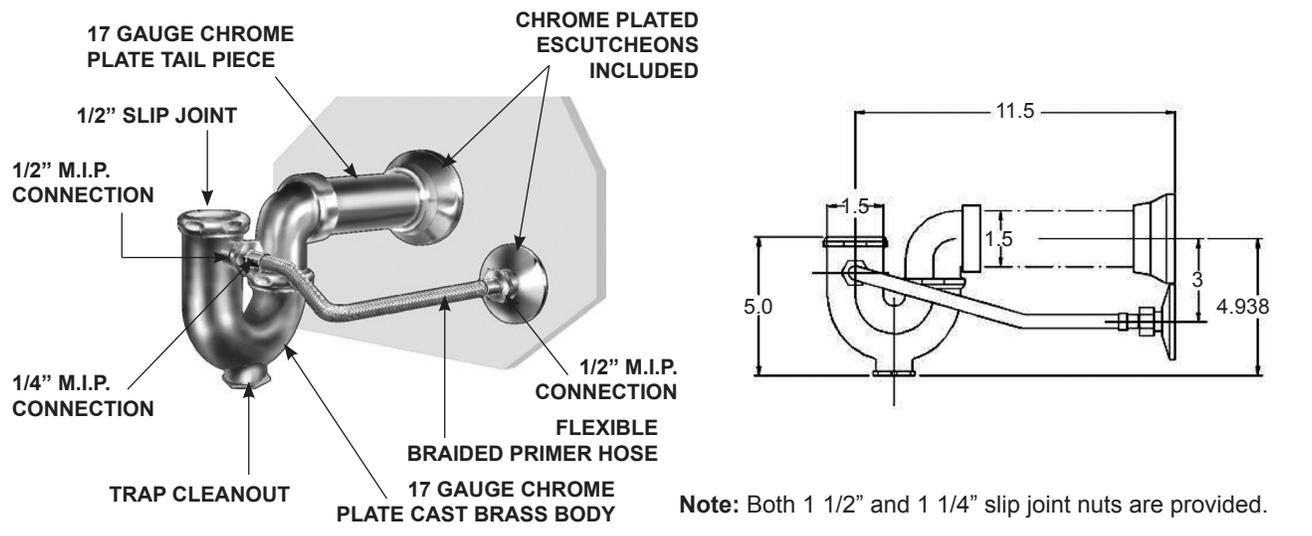

MODEL NUMBER	DESCRIPTION	LIST PRICE
MI-750	Tailpiece Trap Seal Primer	SEE MPB PRICE BOOK

Design and dimensions are subject to modification. Prices do not include applicable taxes.

Visit www.mifab.com for the most recent product information.

MIFAB, Inc., 1321 West 119th Street, Chicago, Illinois 60643-5109, USA

Toll Free: 1-800-465-2736, Fax: 1-773-341-3049

All sales subject to MIFAB's Terms and Warranties. Please refer to page 26.

www.mifab.com • sales@mifab.com • Canada Toll Free: 1-800-387-3880

MI-600-50

CAST IRON P-TRAP SEAL PRIMER CONNECTOR

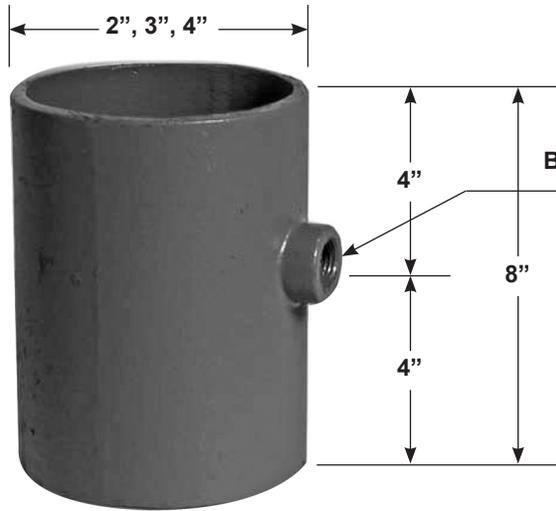

TRAP PRIMER BOSS WITH 1/2" N.P.T. TAPPING

MODEL NUMBER	PIPE SIZE	DESCRIPTION	LIST PRICE
MI-602,3,4-50	2", 3", 4"	Cast Iron Trap Primer Adapter	SEE MPB PRICE BOOK

MI-600-50 SERIES OPTIONAL VARIATIONS:		
SUFFIX	DESCRIPTION	LIST PRICE
-13	All galvanized	SEE MPB PRICE BOOK

MI-600

ABS OR PVC "P-TRAP" TRAP SEAL PRIMER CONNECTOR

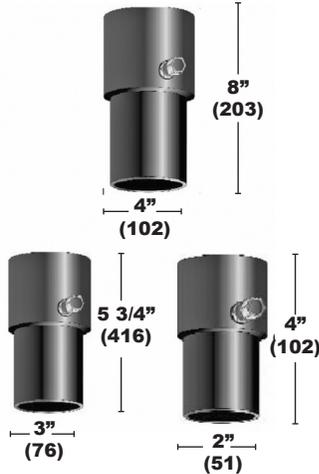

MODEL NUMBER	CONNECTION SIZE	DESCRIPTION COMPRESSION	SHIPPING MATERIAL	CARTON WEIGHT	CARTON QTY.	WEIGHT	LIST PRICE
MI-602	2"	1/2"	ABS	.30 lbs.	24	7.20 lbs.	\$30.00
MI-603	3"	1/2"	ABS	.50 lbs.	18	9.00 lbs.	\$32.00
MI-604	4"	1/2"	ABS	.70 lbs.	12	8.40 lbs.	\$35.00
MI-612	2"	5/8"	ABS	.30 lbs.	24	7.20 lbs.	\$30.00
MI-613	3"	5/8"	ABS	.50 lbs.	18	9.00 lbs.	\$32.00
MI-614	4"	5/8"	ABS	.70 lbs.	24	8.40 lbs.	\$35.00
MI-622	2"	1/2"	PVC	.30 lbs.	24	7.20 lbs.	\$30.00
MI-623	3"	1/2"	PVC	.50 lbs.	18	9.00 lbs.	\$32.00
MI-624	4"	1/2"	PVC	.70 lbs.	12	8.40 lbs.	\$35.00
MI-632	2"	5/8"	PVC	.30 lbs.	24	7.20 lbs.	\$30.00
MI-633	3"	5/8"	PVC	.50 lbs.	18	9.00 lbs.	\$32.00
MI-634	4"	5/8"	PVC	.70 lbs.	12	8.40 lbs.	\$35.00

MI-TEMP-NPB

AUTOMATIC PRESSURE BALANCE VALVE



The MI-TEMP-NPB holds a selected water temperature to within one degree from any constant hot water supply regardless of pressure changes in the supply lines. It ensures a blend of mixed hot and cold water at the shower head and is fully automatic - only one moving part will equalize the hot and cold supply line pressures. As supply line pressures fluctuate, the brass piston will move enough to compensate for the change in pressure and release water only at the preselected temperature.

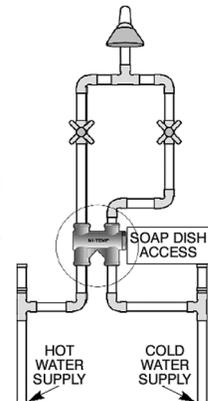

INSTALLATION: The MI-TEMP-NPB can be installed anywhere on a 1/2" (13) water supply line at any angle or position ahead of the control valve(s). When not equipped with an integral shutoff or where there is a shutoff valve installed after the control valve, there shall be stop and check valves on the inlet(s). It can be used with one or two handle valve assemblies and does not need to be installed level. Do not make direct, high temperature soldering connections to the valve body. When making a copper sweat connection, make the adapter solder joint first, then screw the connector into the valve body. The MI-TEMP-NPB should be provided with some type of access for servicing if necessary. The MI-TEMP-NPB can be installed in commercial, institutional, government, educational and residential locations - anywhere a control of water temperature is required. Do not install the MI-TEMP-NPB until ready for final inspection. Standing water will render the valve inoperable. See MI-TEMP-NPB specification sheet on www.mifab.com for maintenance instructions.

MODEL NO.	DESCRIPTION	FLOW RATE	LIST PRICE	SHIPPING WT.	CARTON QTY.	CARTON WT.
MI-TEMP-NPB	Automatic Pressure Balance Valve	12 GPM	\$185.00	1.60 lbs.	30	48 lbs.
MI-TEMP-RK	Repair kit for MI-TEMP	12 GPM	\$80.00	0.30 lbs.	1	0.30 lbs.

Design and dimensions are subject to modification. Prices do not include applicable taxes.

Visit www.mifab.com for the most recent product information.

MIFAB, Inc., 1321 West 119th Street, Chicago, Illinois 60643-5109, USA

Toll Free: 1-800-465-2736, Fax: 1-773-341-3049

All sales subject to MIFAB's Terms and Warranties. Please refer to page 26.

www.mifab.com • sales@mifab.com • Canada Toll Free: 1-800-387-3880

MI-GARD® FLOOR DRAIN TRAP SEAL

Specification: MIFAB MI-GARD® Series inline floor drain trap seal with UV resistant ABS plastic frame, silicon rubber sealing flapper and four flexible sealing ribs. Tested and certified to the ASSE 1072 Standard and listed with IAPMO and I.C.C. Specify connection size (2", 3", 3 1/2" or 4")

Function: Used in the outlet connections of floor drain bodies, or the inside of floor drain strainers to seal the opening to prevent odors, sewer gases, and insects from entering up through the floor drain grate. The MI-GARD®'s four flexible silicone sealing ribs ensure easy installation into openings that have variations in size. The MI-GARD® will open to allow drainage and close when there is no water flow. The MI-GARD® can be used in either new construction or retro-fit applications where trap primers were never installed.

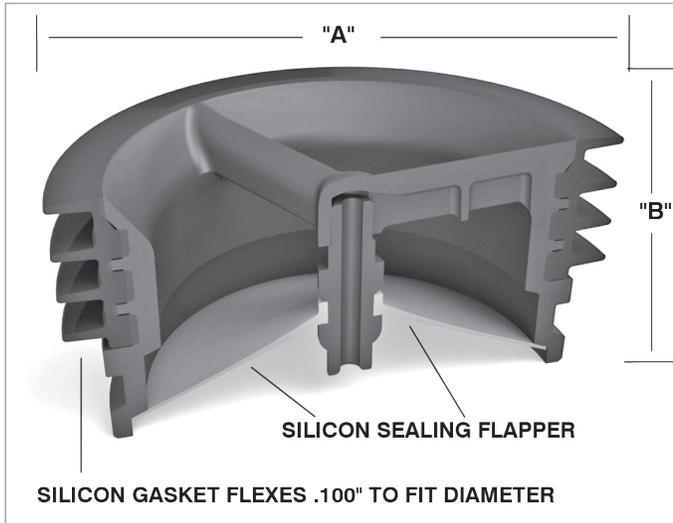

MODEL NUMBER	"A" (PIPE SIZE)	"B" (HEIGHT)
MI-GARD-2	2" (51)	2" (51)
MI-GARD-3	3" (76)	2" (51)
MI-GARD-35	3 1/2" (89)	2" (51)
MI-GARD-4	4" (102)	2" (51)

MI-GARD® prevents the following from entering through the top of floor drains:

- Odors and sewer gases
- Insects

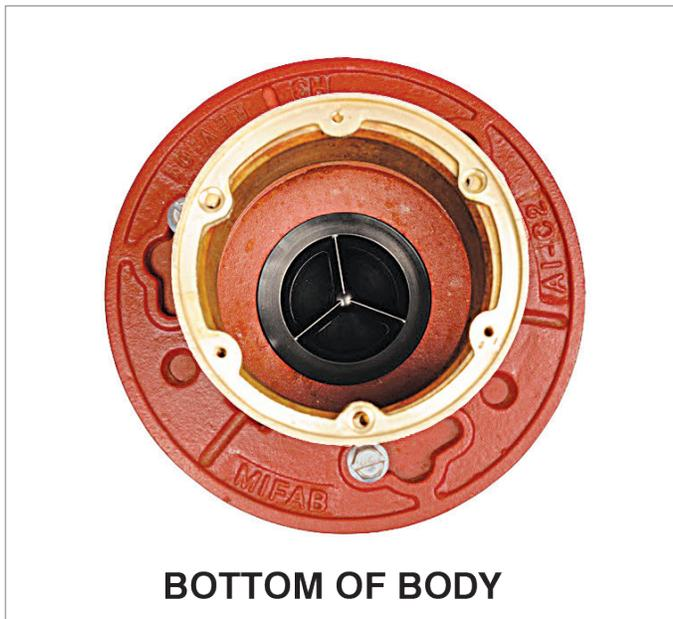

MIFAB – MI-GARD – FLOOR DRAIN TRAP SEAL DEVICE

Installation Instructions: The MI-GARD-2 (2”), MI-GARD-3 (3”), MI-GARD-35 (3 ½”) and MI-GARD-4 (4”) Floor Drain Trap Seal Devices install into either the outlet connections of floor drain bodies or into the inside of floor drain strainers.

To install into the outlet connections of floor drain bodies, remove the grate or strainer and place the appropriate size MI-GARD product (match the opening size 2”, 3”, 3 ½” or 4” with the product size) into the inside of the floor drain body outlet connection. The four flexible silicon exterior sealing ribs ensure easy installation into openings that have variations in size.

To install into the inside of floor drain strainers, remove the grate or strainer and place the appropriate size MI-GARD product (match the opening size 2”, 3”, 3 ½” or 4” with the product size) into the inside of the throat of the strainer. The four flexible silicon exterior sealing ribs ensure easy installation into openings that have variations in size.

LIST PRICES

MODEL NUMBER	SIZE	LIST PRICE	CARTON QUANTITY
MI-GARD-2	2”	\$60.00	24
MI-GARD-3	3”	\$65.00	24
MI-GARD-35	3 ½”	\$80.00	24
MI-GARD-4	4”	\$80.00	24

LIST PRICES FOR REPAIR PARTS - REPLACEMENT SILICON SEALING FLAPPERS

MODEL NUMBER	DESCRIPTION	LIST PRICE
MI-GARD-2-FLAP	Replacement silicon sealing flapper for MI-GARD-2	\$30.00
MI-GARD-3-FLAP	Replacement silicon sealing flapper for MI-GARD-3	\$32.50
MI-GARD-35-FLAP	Replacement silicon sealing flapper for MI-GARD-35	\$40.00
MI-GARD-4-FLAP	Replacement silicon sealing flapper for MI-GARD-4	\$40.00

The silicon sealing flapper can be easily removed from all MI-GARD models and replaced with a new flapper.



Design and dimensions are subject to modification. Prices do not include applicable taxes.

Visit www.mifab.com for the most recent product information.

MIFAB, Inc., 1321 West 119th Street, Chicago, Illinois 60643-5109, USA

Toll Free: 1-800-465-2736, Fax: 1-773-341-3049

All sales subject to MIFAB's Terms and Warranties. Please refer to page 26.

www.mifab.com • sales@mifab.com • Canada Toll Free: 1-800-387-3880

CL-NPB / CLS-NPB PISTON TYPE WATER HAMMER ARRESTORS



CL-AA-NPB illustrated

- Thick walled one piece, hard drawn “K”copper seamless body. Unique design eliminates separate end cap connection to ensure maximum integrity of the body and guarantees free movement of the piston for maximum performance.
- Ryton PPS piston with two Parco #5778-80 O-rings and Dow Corning #111 FDA approved silicone lubricant. Ribbed piston design reduces secondary shock and flared piston skirt prevents hard particles suspended in the water supply from contacting the O-rings to provide increased product life.
- Large volume air chamber provides better dampening for superior water hammer arrestor performance.
- Temperature range: Maximum working temperature is 250° F.
- Operating pressure: Up to 350 PSIG
- Surge pressure: Up to 1,500 PSIG
- No access door is required to service MIFAB’s water hammer arrestors.

Tested and certified to the A.S.S.E. 1010 and A.N.S.I. A112.26.4M Standards and listed with I.A.P.M.O. **Patent # 6,539,976**



CLS-AA-1/2-NPB illustrated

CLS SERIES					
MODEL NUMBER	SINGLE PIECE WT.	DESCRIPTION	UNIT FIXTURE	UNITS PER BOX	LIST PRICE PER UNIT
CLS-AA-1/2-NPB	.30 lbs.	1/2" male sweat connection	1-3	50	\$13.45
CLS-AA-3/4-NPB	.35 lbs.	3/4" male sweat connection	1-3	50	\$17.00

MODEL NUMBER	FIXTURE UNITS	(A) LENGTH	SWT. CONN. SIZE	SINGLE PIECE WEIGHT	MASTER CARTON QTY.	MASTER CARTON WT.	LIST PRICE PER UNIT
CLS-A-NPB	1-11	8-1/4"	1/2"	.52 lbs.	44	23 lbs.	\$18.20
CLS-B-NPB	12-30	10"	3/4"	.75 lbs.	32	24 lbs.	\$21.75
CLS-C-NPB	31-60	12-1/2"	1"	1.39 lbs.	22	30.5 lbs.	\$53.00
CLS-D-NPB	61-113	11"	1"	2.06 lbs.	8	16.5 lbs.	\$68.00
CLS-E-NPB	114-154	13-1/2"	1"	2.5 lbs.	7	17.5 lbs.	\$91.00
CLS-F-NPB	155-330	16"	1"	2.92 lbs.	6	17.5 lbs.	\$139.00

CL SERIES								
MODEL NUMBER	ASSE RATING	FIXTURE UNITS	(A) LENGTH	(B) THREADED CONNECTION SIZE	SINGLE PIECE WEIGHT	MASTER CARTON QTY.	MASTER CARTON WT.	LIST PRICE PER UNIT
CL-AA-NPB	AA	1-3	4-3/4"	1/2"	.33 lbs.	50	16.5 lbs.	\$14.50
CL-A-NPB	A	1-11	6"	1/2"	.45 lbs.	60	27 lbs.	\$20.00
CL-B-NPB	B	12-30	7-1/2"	3/4"	.55 lbs.	42	23 lbs.	\$24.00
CL-C-NPB	C	31-60	9"	1"	1 lb.	24	24 lbs.	\$57.25
CL-D-NPB	D	61-113	10-1/2"	1-1/4"	2.38 lbs.	8	19 lbs.	\$74.50
CL-E-NPB	E	114-154	11-1/4"	1-1/2"	3 lbs.	6	18 lbs.	\$99.50
CL-F-NPB	F	155-330	13"	2"	5.83 lbs.	6	35 lbs.	\$150.00

Design and dimensions are subject to modification. Prices do not include applicable taxes.

Visit www.mifab.com for the most recent product information.

MIFAB, Inc., 1321 West 119th Street, Chicago, Illinois 60643-5109, USA

Toll Free: 1-800-465-2736, Fax: 1-773-341-3049

All sales subject to MIFAB's Terms and Warranties. Please refer to page 26.

www.mifab.com • sales@mifab.com • Canada Toll Free: 1-800-387-3880

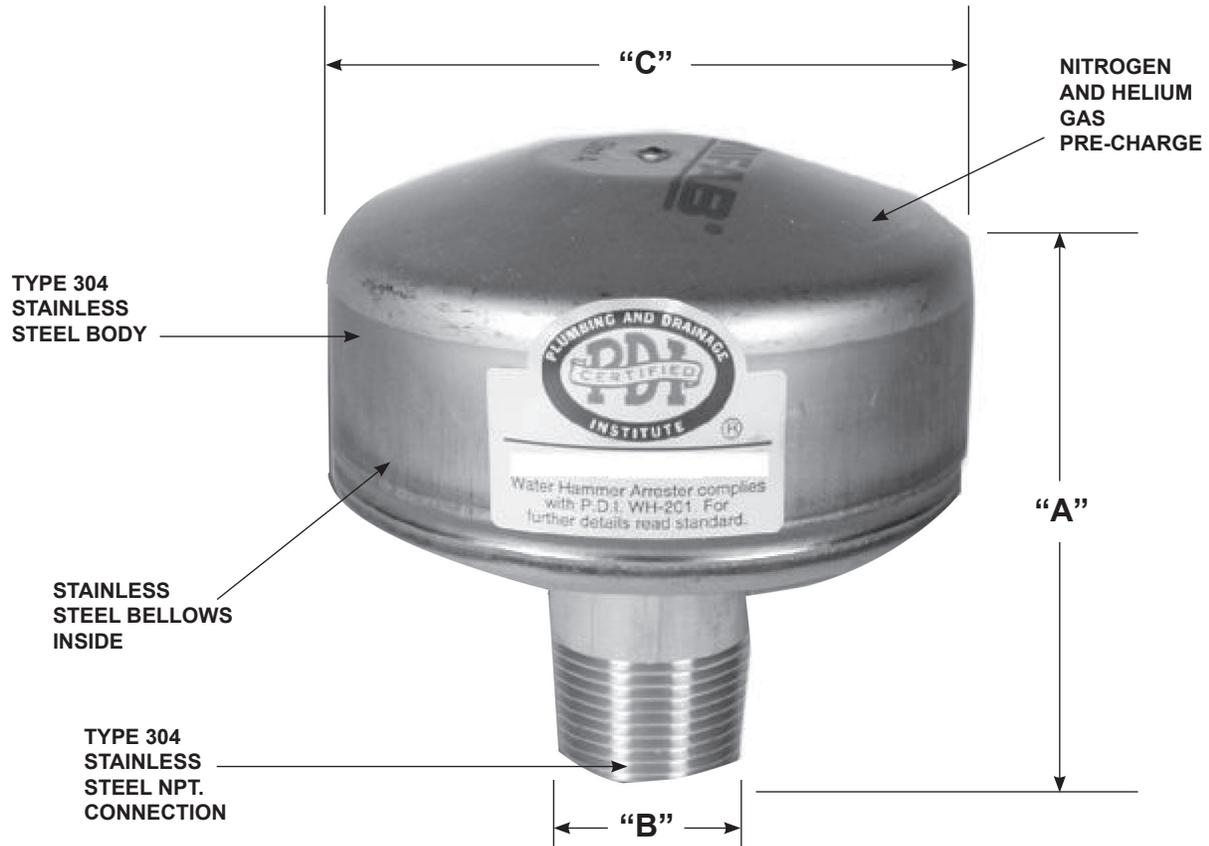
WHB
STAINLESS STEEL BELLOWS WATER HAMMER ARRESTORS

MODEL NUMBER	PDI RATING	FIXTURE UNITS	PIPE SIZE	"A" HEIGHT	"B" CONN. SIZE	"C" DIAMETER	LIST PRICE
WHB-A	A	1-11	3/4"	3 3/8"	3/4"	3 3/8"	See MPB Price Book
WHB-B	B	12-30	1"	4"	1"	3 3/8"	See MPB Price Book
WHB-C	C	31-60	1"	4 3/8"	1"	3 3/8"	See MPB Price Book
WHB-D	D	61-113	1"	5 3/8"	1"	3 3/8"	See MPB Price Book
WHB-E	E	114-154	1"	7 1/4"	1"	3 3/8"	See MPB Price Book
WHB-F	F	155-330	1"	7 1/4"	1"	3 3/8"	See MPB Price Book

Note: Specify suffix –BA for Buy America Act and/or American Recovery and Reinvestment Act compliant product.

WATER HAMMER ARRESTOR SIZING

Single and Multiple Fixture Branch Lines **Table One**

The water hammer arrestor sizing procedure for single and multiple fixtures described below conforms to that established by the American Society of Sanitary Engineers in their Standard ASSE-1010. Selection of the water hammer arrestor is based upon the total quantity of Fixture-Units on each cold and hot water branch line.

Fixture-Unit Listing

Determine the total number of Fixture-Units on each branch line by referring to the list of fixtures in Table One.

Water Hammer Arrestor Selection

Refer to Table Two and select the water hammer arrestor model with proper Fixture-Unit capacity. In long batteries of fixtures over 20 feet in length, more than one water hammer arrestor will be required.

(See placement data shown below.)

Fixture	Type of Supply Control	Weight in Fixture Units			
		Public		Private	
		C.W.	H.W.	C.W.	H.W.
Water Closet	Flush Valve	10	-	6	-
Water Closet	Flush Tank	5	-	3	-
Pedestrial Urinal	Flush Valve	10	-	-	-
Stall or Wall Urinal	Flush Valve	5	-	-	-
Stall or Wall Urinal	Flush Tank	3	-	-	-
Lavatory	Faucet	1 1/2	1 1/2	1	1
Bathtub	Faucet	2	2	1 1/2	1 1/2
Shower Head	Mixing Valve	2	2	1	2
Bathroom Group	Flush Valve Closet	-	-	8	3
Bathroom Group	Flush Tank Closet	-	-	6	3
Separate Shower	Mixing Valve	-	-	1	2
Service Sink	Faucet	3	3	-	-
Laundry Tubs (1-3)	Faucet	-	-	3	3
Combination Fixture	Faucet	-	-	3	3

WATER HAMMER ARRESTOR PLACEMENT DATA

On multiple fixture branch lines up to 20 feet in length, the water hammer arrestor should be installed on the branch line between the last two fixtures being served. The water hammer arrestor should have a Fixture-Unit rating equal to or greater than the total Fixture-Units connected to the branch line.

On multiple fixture branch lines over 20 feet in length, two water hammer arrestors should be used on each line with the second unit placed at the approximate midpoint of the line. The sum of the Fixture-Unit ratings of the water hammer arrestors on each branch should be equal to or greater than the total Fixture-Units connected to the branch line.

Table Two

Water Hammer Arrestor Model No.	A	B	C	D	E	F
Fixture Unit Capacity	1-11	12-32	33-60	61-113	114-154	155-330

NOTES:

- (1) All sizing data in this book are based on flow velocities of 10 feet per second or less.
- (2) When the static water pressure in the line exceeds 65 psig, contact the MIFAB Engineer Department.
- (3) If the fixture-unit total has 1/2" fraction, it is to be "rounded-up" to the next larger whole number. If the total is 11 1/2 fixture units, use 12 fixture units.

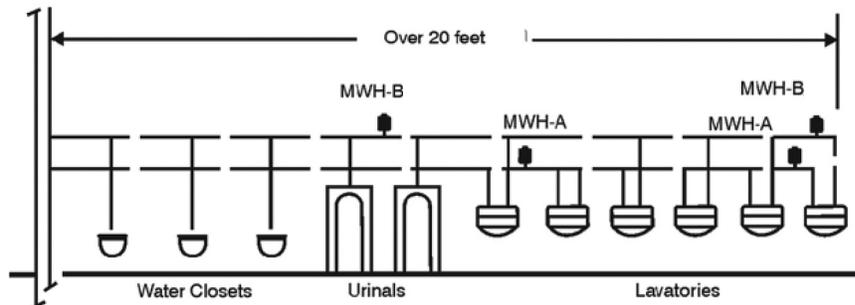
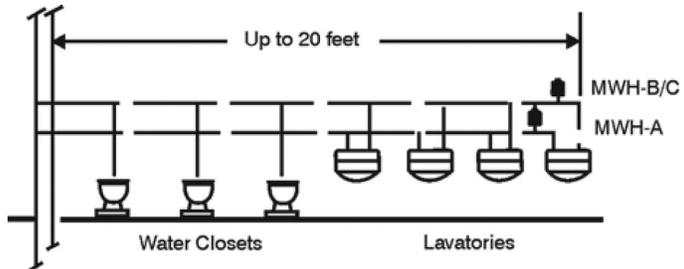

WHS
WATER HAMMER ARRESTORS FOR HEAVY EQUIPMENT

MODEL NUMBER	NOMINAL GAS CAPACITY (Cubic Inches)	FLUID DISPLACEMENT (Cubic Inches)	HOUSING SIZE DIA. (Inches)	HOUSING SIZE HEIGHT (Inches)	CONNECTION SIZE	APPROXIMATE WEIGHT (LBS.)	LIST PRICE
WHS-11	100	60	10 1/2"	8"	2" Nipple	70	P.O.A.
WHS-12	200	120	10 1/2"	10"	2" Nipple	80	P.O.A.
WHS-13	500	300	16"	10 3/4"	2" Nipple	140	P.O.A.
WHS-14	1,000	600	16"	14"	2" Nipple	150	P.O.A.
WHS-15	2,000	1,200	24"	18"	3" Flange	300	P.O.A.
WHS-16	5,000	3,000	24"	22 3/4"	3" Flange	350	P.O.A.
WHS-17	10,000	6,000	36"	25"	4" Flange	570	P.O.A.
WHS-17S	25,000	15,000	42"	40"	6" Flange	2200	P.O.A.
WHS-18	50,000	30,000	48"	47"	6" Flange	3000	P.O.A.

Design and dimensions are subject to modification. Prices do not include applicable taxes.

 Visit www.mifab.com for the most recent product information.

MIFAB, Inc., 1321 West 119th Street, Chicago, Illinois 60643-5109, USA

Toll Free: 1-800-465-2736, Fax: 1-773-341-3049

All sales subject to MIFAB's Terms and Warranties. Please refer to page 26.

www.mifab.com • sales@mifab.com • Canada Toll Free: 1-800-387-3880

IAPMO RESEARCH AND TESTING, INC.

5001 E. Philadelphia Street, Ontario, CA 91761-2816 • (909) 472-4100 • Fax (909) 472-4244 • www.iapmort.org



CERTIFICATE OF LISTING

IAPMO Research and Testing, Inc. is a product certification body which tests and inspects samples taken from the supplier's stock or from the market or a combination of both to verify compliance to the requirements of applicable codes and standards. This activity is coupled with periodic surveillance of the supplier's factory and warehouses as well as the assessment of the supplier's Quality Assurance System. This listing is subject to the conditions set forth in the characteristics below and is not to be construed as any recommendation, assurance or guarantee by IAPMO Research and Testing, Inc. of the product acceptance by Authorities Having Jurisdiction.

The most updated information on this Certificate of Listing is available online at pld.iapmo.org

Effective Date: October 2014 Void After: October 2015

Product: Trap Seal Primer Devices □ Drainage Types and Electronic Design Types File No. 7746

Issued To: MIFAB, INC.
1321 WEST 119TH STREET
CHICAGO, IL 60643

Identification: Cast brass elbows shall contain the manufacturer's name or trademark, and model number. The product shall also bear the UPC® certification mark.

Characteristics: Cast brass p-trap/trap primer utilizing grey water from a plumbing fixture. To be installed in accordance with the manufacturer's instructions and the latest edition of the Uniform Plumbing Code.

Products listed on this certificate have been tested by an IAPMO R&T recognized laboratory. This recognition has been granted based upon the laboratory's compliance to the applicable requirements of ISO/IEC 17025.

Products are in compliance with the following code(s):

Uniform Plumbing Code (UPC®)

Products are in compliance with the following standard(s):

ASSE 1044-2001

MODELS:

MI-100-5
MI-100-10
MI-100-15
MI-100-20
MI-100-25
MI-100-30
MI-100-35
MI-200
MI-300

IAPMO RESEARCH AND TESTING, INC.

5001 E. Philadelphia Street, Ontario, CA 91761-2816 • (909) 472-4100 • Fax (909) 472-4244 • www.iapmort.org



CERTIFICATE OF LISTING

IAPMO Research and Testing, Inc. is a product certification body which tests and inspects samples taken from the supplier's stock or from the market or a combination of both to verify compliance to the requirements of applicable codes and standards. This activity is coupled with periodic surveillance of the supplier's factory and warehouses as well as the assessment of the supplier's Quality Assurance System. This listing is subject to the conditions set forth in the characteristics below and is not to be construed as any recommendation, assurance or guarantee by IAPMO Research and Testing, Inc. of the product acceptance by Authorities Having Jurisdiction.

The most updated information on this Certificate of Listing is available online at pld.iapmo.org

Effective Date: November 2014 Void After: November 2015

Product: Trap Seal Primers Valves File No. 3823

Issued To: MIFAB, INC.
1321 WEST 119TH STREET
CHICAGO, IL 60643

Identification: Marking shall be permanently affixed to, stamped or cast on the body of the valve with manufacturer's name or marketers name or trademark, operating range, model number or other identification. The product shall also bear the UPC® certification mark.

Characteristics: Trap seal primer valves designed for water working pressure of at least 125 psi (961 KPa) and to supply water to the trap to provide and maintain its water seal. Supply line and trap makeup water supply connections shall be minimum 1/2" (12.7 mm) pipe size. To be installed in accordance with the manufactures instructions and the requirements of the Uniform Plumbing Code.

Products listed on this certificate have been tested by an IAPMO R&T recognized laboratory. This recognition has been granted based upon the laboratory's compliance to the applicable requirements of ISO/IEC 17025.

Products are in compliance with the following code(s):

Uniform Plumbing Code (UPC®)
International Plumbing Code (IPC®)

Products are in compliance with the following standard(s):

ASSE 1018-2001

MODELS:

MI-DU, MI-TSP-1, MI-TSP-2,
MI-TSP-3, MR-500, MI-500,
M2-500

MODELS:

MI-DU, MI-TSP-1, MI-TSP-2,
MI-TSP-3, MR-500, MI-500,
M2-500



Certification Record

CUSTOMER	CLASS	FILE
MIFAB, Inc. 1321 West 119th St, Chicago IL 60643 USA	6803-10 PLUMBING FITTINGS-Trap Primers	110892_0_000
Refer to Class Description for program details		

ε Trap Seal Primer Valves: MI-TSP-1, MI-TSP-2, MI-TSP-3, MR-500, MI-500, M2-500.

/sp

Copyright © 2012 CSA International. All rights reserved.

IAPMO RESEARCH AND TESTING, INC.

5001 E. Philadelphia Street, Ontario, CA 91761-2816 • (909) 472-4100 • Fax (909) 472-4244 • www.iapmort.org



CERTIFICATE OF LISTING

IAPMO Research and Testing, Inc. is a product certification body which tests and inspects samples taken from the supplier's stock or from the market or a combination of both to verify compliance to the requirements of applicable codes and standards. This activity is coupled with periodic surveillance of the supplier's factory and warehouses as well as the assessment of the supplier's Quality Assurance System. This listing is subject to the conditions set forth in the characteristics below and is not to be construed as any recommendation, assurance or guarantee by IAPMO Research and Testing, Inc. of the product acceptance by Authorities Having Jurisdiction.

The most updated information on this Certificate of Listing is available online at pld.iapmo.org

Effective Date: May 2014 -Rev. 7/15/2014- Void After: May 2015

Product: Lead Free Plumbing Products File No. 6798

Issued To: MIFAB, INC.
1321 WEST 119TH STREET
CHICAGO, IL 60643-5109

Identification: Each product shall bear permanent and legible markings to identify the manufacturer. This marking shall be the trade name, trademark, or other mark known to identify the manufacturer. The product and/or product packaging may also bear the term "Lead Plumbing Law", "Complies with Lead Plumbing Law", or either "Lead Free" or "Low Lead" above or in close proximity to the appropriate IAPMO R&T certification mark, or the term "Certified by IAPMO R&T". The product packaging may also bear a grey dot, a check mark with circle, or any other home centers marking requirements.

Characteristics: Products may include any pipe, pipe fitting, solder, flux, or other plumbing products providing water for human consumption. Products listed below are to be installed in accordance with the manufacturer's instruction. These products have been verified with weighted average lead content $\leq 0.25\%$; Solder and flux lead content $\leq 0.2\%$.

Products listed on this certificate have been tested by an IAPMO R&T recognized laboratory. This recognition has been granted based upon the laboratory's compliance to the applicable requirements of ISO/IEC 17025.

Products are in compliance with the following standard(s):

Section 1417(d) of the Safe Drinking Water Act
The lead content requirements of Section 116875 of the California Health & Safety Code

MODELS:

M1-500-MPB
M2-500NPB
MI-100-10
MI-100-15
MI-100-20
MI-100-25
MI-100-30
MI-100-35
MI-100-5
MI-TEMP-NPB Automatic Pressure Balance Valve
MR-500-NPB

TRAP SEAL PRIMER TROUBLESHOOTING

Following are some things to trouble shoot when it comes to our M-500-NPB Series of Trap Seal Primers (M1-500-NPB, M2-500-NPB, MR-500-NPB):

1) What is the line pressure for the installation?

The M-500-NPB Series of trap seal primers will work within a line pressure range of 35 – 80 psi. Do not subject the trap seal primer to pressure in excess of 80 psi. The trap seal primer must be installed on a cold fresh water line of 1 1/2" diameter or less.

2) How far away is the trap primer from the source of the pressure drop?

Anything farther away than 20 feet is an issue, as the farther the primer is away from the source of the pressure drop, the less likely it will sense it and work.

3) What is the pressure drop where the primer is?

MIFAB's M-500-NPB Series of primers will work with as little as 3 psi in pressure drop. With today's low flow and consumption faucets, there is less pressure drop being created when the faucets and toilets are used. Therefore, it is recommended to install the trap seal primer as close to the low flow fixture as possible.

4) Water hammer arrestors on the line can also affect pressure drop in the line.

It would be best to get a pressure reading where the trap primer is installed. The M-500-NPB series needs a fast, sharp pressure drop to activate. The long pipe run to the trap primer and the water hammer arrestor may not be allowing the trap primer to function properly.

5) Look at the gauge fluctuation

Is it a quick and sharp pressure drop? Or did it gradually drop? The trap primers need a quick pressure drop to activate. A slow gradual pressure drop may not be enough to activate the M-500-NPB. That is why we state that they should be as close to the pressure drop source as possible. The M1-500-NPB has the most buoyant cartridge and should perform the best. If the trap primer looked good and was filled with water then it is the rate of the pressure drop that is causing the issue.

6) Water heaters

Do not install the trap seal primer on a water heater line due to insufficient pressure drop.

7) Not working

In some cases, the installation conditions cannot deliver the required 3 psi pressure drop to activate MIFAB's MR-500-NPB, M1-500-NPB and / or M2-500-NPB trap seal primers. In such cases, MIFAB recommends the use of the MI-TSP-1-NPB (page 5) continuous flow trap seal primer which does not require a pressure drop to activate or the MI-100 (page 6) Series of electronic trap seal primers which also do not require a pressure drop and are electronically programmed to deliver a specific amount of water at specific time intervals. Also refer to the copy in the Trap Seal Primer section (Pages 1-4).

M-500-NPB SERIES INSTALLATION INSTRUCTIONS:

Use a 1 1/8" open end wrench to install the M-500-NPB Series of trap seal primers to the line by using the flats on the top of the trap seal primer. Water lines must be flushed before installing MIFAB's MR-500-NPB Series of trap seal primers. The leading cause of trap seal primer performance problems is interference from foreign debris. The trap seal primers should be cycled at least six times to reduce problems of interference from foreign debris. The following steps are highly recommended:

- Ensure that all flux and other debris is removed from supply line to the primer.
- Use only teflon tape around threads, NEVER use pipe dope.
- Do not solder fittings directly onto the inlet or outlet of the primer, as the primer uses a PE (polyethylene) cartridge.

Failure to follow these instructions will negatively affect performance of the product. MIFAB's primers have a unique design which allows the primer to be taken apart and cleaned before re-assembly. Do this in the event of excess water discharge.

Trap seal primers should be mounted one foot above the finished floor for every twenty feet of floor drain trap make-up water line. For easy access to the trap seal primer, install a union connection above it. Install a line shut off valve upstream of the trap seal primer in order to shut off the water supply when performing maintenance on the trap seal primer.

INSPECTION INSTRUCTIONS:

After installing and pre-cycling the trap seal primer, use any of the four holes to view water discharge from the orifice. A light can be placed opposite the viewing hole to improve clarity in this inspection.

MAINTENANCE INSTRUCTIONS:

In order to replace the filter screen, remove the trap seal primer by using an open end wrench on the top set of flats. Grasp the top of the filter screen with fingers, squeeze and remove the filter. Insert the new filter screen by squeezing and pushing it firmly down into the top of the trap seal primer. Re-install the trap seal primer using the top set of flats. In regions that experience heavy residual deposits such as calcium in the water supply, MIFAB's M-500-NPB Series of trap seal primers can be field refurbished by removing the bottom end of the primer, and replacing the cartridge.

Go to www.mifab.com for more information on maintenance of trap seal primers.

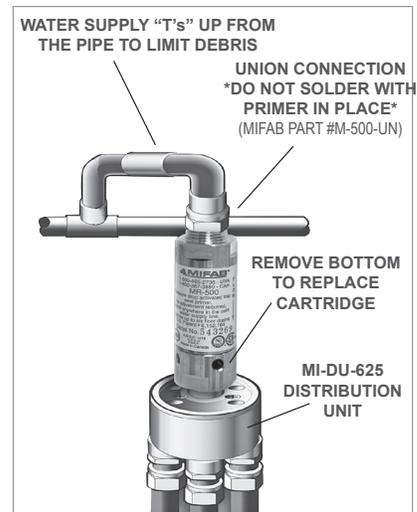

CROSS REFERENCE

PPP TO MIFAB

PPP	MIFAB
AP-500.....(pg.10).....	MI-200
Auto Prime.....(pg.6).....	MI-100
CPO-500.....(pg.4).....	MR-500
FVP-1VB.....(pg.12).....	MI-702
LPT-1500.....(pg.12).....	MI-750
MP-500-12v.....(pg.10).....	MI-300-24VDC
MP-500-115v.....(pg.10).....	MI-300-120VAC
MPB-500.....(pg.12).....	MI-300-BP
Mini Prime.....(pg.10).....	MI-300
Oregon # 1.....(pg.4).....	MR-500
P-1.....(pg.4).....	M1-500
P1-500.....(pg.4).....	M1-500
P-2.....(pg.4).....	M2-500
P2-500.....(pg.4).....	M2-500
PO-500.....(pg.4).....	MR-500
PR-500.....(pg.4).....	MR-500
PR-500NP.....(pg.4).....	MI-200-24VDC*
PR-500SS.....(pg.4).....	MR-500-SS
Prime - Rite.....(pg.4).....	MR-500
PRO1-500.....(pg.5).....	MI-TSP-1
PT Series.....(pg.6).....	MI-100
PTS.....(pg.6).....	MI-100
Solo Prime.....(pg.10).....	MI-200
SP-500-24v.....(pg.10).....	MI-200-24VDC*
SP-500-115v.....(pg.10).....	MI-200-120VAC

*Note: MIFAB's MI-200-24VDC has a VDC solenoid valve, not a VAC solenoid valve as supplied by PPP.

DISTRIBUTION UNITS

PPP	MIFAB
DU-2-500.....(pg.5).....	MI-DU-500
DU-2-625.....(pg.5).....	MI-DU-625
DU-3-500.....(pg.5).....	MI-DU-500
DU-3-625.....(pg.5).....	MI-DU-625
DU-4-500.....(pg.5).....	MI-DU-500
DU-4-625.....(pg.5).....	MI-DU-625
DU-U-500.....(pg.5).....	MI-DU-500
DU-U-625.....(pg.5).....	MI-DU-625

PRESSURE BALANCE VALVES

PPP	MIFAB
TCP-2.....(pg.13).....	MI-TEMP
TRB-2.....(pg.13).....	MI-TEMP

AIR GAP FITTINGS

PPP	MIFAB
AG-500.....(See MPB-2015).....	MI-GAP
RVAG-750CTH.....(See MPB-2015).....	MI-GAP

P-TRAP ADAPTORS

PPP	MIFAB
PPA-2A.....(pg.13).....	MI-602 / MI-612
PPA-3A.....(pg.13).....	MI-603 / MI-613
PPA-4A.....(pg.13).....	MI-604 / MI-614
PPA-2P.....(pg.13).....	MI-622 / MI-632
PPA-3P.....(pg.13).....	MI-623 / MI-633
PPA-4P.....(pg.12).....	MI-624 / MI-634

WATER HAMMER ARRESTORS

PPP	MIFAB
MM-500 SWA.....(pg.16).....	CLS-AA-1/2
MM-500 TH.....(pg.16).....	CL-AA-1/2
SC-500.....(pg.16).....	CL-A
SC-500A.....(pg.16).....	CL-A

SC-750.....(pg.16).....	CL-B
SC-750B.....(pg.16).....	CL-B
SC-1000.....(pg.16).....	CL-C
SC-1000C.....(pg.16).....	CL-C

PPP TO MIFAB

PPP	MIFAB
SC-1250.....(pg.16).....	CL-D
SC-1250D.....(pg.16).....	CL-D
SC-1500.....(pg.16).....	CL-E
SC-1500E.....(pg.16).....	CL-E
SC-2000.....(pg.16).....	CL-F
SC-2000F.....(pg.16).....	CL-F
SWA-500.....(pg.16).....	CLS-A
SWA-750.....(pg.16).....	CLS-B
SWA-1000.....(pg.16).....	CLS-C
SWA-1250.....(pg.16).....	CLS-D
SWA-1500.....(pg.16).....	CLS-E
SWA-2000.....(pg.16).....	CLS-F

SIoux CHIEF TO MIFAB

TRAP SEAL PRIMERS

Sioux Chief	MIFAB
695-01.....(pg.4).....	MR-500
695-Y52.....(pg.5).....	MI-DU
695-D20.....(pg.5).....	MI-DU
695-D30.....(pg.5).....	MI-DU
695-D40.....(pg.5).....	MI-DU
695-D432.....(pg.5).....	MI-DU
695-D432F.....(pg.5).....	MI-DU
695-D432S.....(pg.5).....	MI-DU

WATER HAMMER ARRESTORS

Sioux Chief	MIFAB
660-2.....(pg.16).....	CL-A
652-A.....(pg.16).....	CL-A
653-B.....(pg.16).....	CL-B
654-C.....(pg.16).....	CL-C
655-D.....(pg.16).....	CL-D
656-E.....(pg.16).....	CL-E
657-F.....(pg.16).....	CL-F
660-S.....(pg.16).....	CLS-A
652-AS.....(pg.16).....	CLS-A
653-BS.....(pg.16).....	CLS-B
654-CS.....(pg.16).....	CLS-C
655-DS.....(pg.16).....	CLS-D
656-ES.....(pg.16).....	CLS-E
657-FS.....(pg.16).....	CLS-F
660-S.....(pg.16).....	CLS-AA-1/2
660-3S.....(pg.16).....	CLS-AA-3/4
660-2.....(pg.16).....	CL-AA

JAY R. SMITH TO MIFAB

TRAP SEAL PRIMERS

JRS	MIFAB
260-SC.....(pg.5).....	MI-TSP-1 / MI-DU
260-T.....(pg.5).....	MI-TSP-2 / MI-DU
261-SC.....(pg.5).....	MI-TSP-1
261-T.....(pg.5).....	MI-TSP-2
2698.....(pg.12).....	MI-750
2699.....(pg.5).....	MI-TSP-2
2699-1.....(pg.5).....	MI-TSP-1

WATER HAMMER ARRESTORS

JRS	MIFAB
520-SC-AA.....(pg.16).....	CLS-AA-1/2
520-SC-A.....(pg.16).....	CLS-A

520-SC-B.....(pg.16).....	CLS-B
520-SC-C.....(pg.16).....	CLS-C
520-SC-D.....(pg.16).....	CLS-D
520-SC-E.....(pg.16).....	CLS-E
520-SC-F.....(pg.16).....	CLS-F
520-T-AA.....(pg.16).....	CL-AA-1/2
520-T-A.....(pg.16).....	CL-A

JAY R. SMITH TO MIFAB

JRS	MIFAB
520-T-B.....(pg.16).....	CL-B
520-T-C.....(pg.16).....	CL-C
520-T-D.....(pg.16).....	CL-D
520-T-E.....(pg.16).....	CL-E
520-T-F.....(pg.16).....	CL-F
5005.....(pg.17).....	WHB-A
5010.....(pg.17).....	WHB-B
5020.....(pg.17).....	WHB-C
5030.....(pg.17).....	WHB-D
5040.....(pg.17).....	WHB-E
5050.....(pg.17).....	WHB-F
5205.....(pg.16).....	CL-A
5210.....(pg.16).....	CL-B
5220.....(pg.16).....	CL-C
5230.....(pg.16).....	CL-D

JOSAM TO MIFAB

TRAP SEAL PRIMERS

JOSAM	MIFAB
88250.....(pg.5).....	MI-TSP-2
88250-90.....(pg.5).....	MI-TSP-1
88250-91.....(pg.5).....	MI-TSP-3
88300.....(pg.4).....	MR-500

WATER HAMMER ARRESTORS

JOSAM	MIFAB
75001-A.....(pg.17).....	WHB-A
75002-B.....(pg.17).....	WHB-B
75003-C.....(pg.17).....	WHB-C
75004-D.....(pg.17).....	WHB-D
75005-E.....(pg.17).....	WHB-E
75006-F.....(pg.17).....	WHB-F
75000-S.....(pg.16).....	CL-AA
75001-S.....(pg.16).....	CL-A
75002-S.....(pg.16).....	CL-B
75003-S.....(pg.16).....	CL-C
75004-S.....(pg.16).....	CL-D
75005-S.....(pg.16).....	CL-E
75006-S.....(pg.16).....	CL-F

WADE TO MIFAB

TRAP SEAL PRIMERS

WADE	MIFAB
2400-S.....(pg.5).....	MI-TSP-1
2400-T.....(pg.5).....	MI-TSP-2
2400-MF.....(pg.5).....	MI-DU
2400-M.....(pg.12).....	MI-750
2400-P.....(pg.12).....	MI-750

WATER HAMMER ARRESTORS

WADE	MIFAB
5.....(pg.17).....	WHB-A
10.....(pg.17).....	WHB-B
20.....(pg.17).....	WHB-C
50.....(pg.17).....	WHB-D
75.....(pg.17).....	WHB-E
100.....(pg.17).....	WHB-F
5-P.....(pg.16).....	CL-A
10-P.....(pg.16).....	CL-B

20-P.....(pg.16).....	CL-C
50-P.....(pg.16).....	CL-D
75-P.....(pg.16).....	CL-E
100-P.....(pg.16).....	CL-F

WATTS TO MIFAB

TRAP SEAL PRIMERS

WATTS	MIFAB
TSP.....(See MPB-2015).....	MI-TSP-1
TSP-1.....(See MPB-2015).....	MI-TSP-2
A-200.....(pg.5).....	MI-TSP-2
A200-S.....(pg.5).....	MI-TSP-1
A200T.....(pg.5).....	MI-TSP-2
MS-810.....(pg.5).....	MI-TSP-1

WATER HAMMER ARRESTORS

WATTS	MIFAB
SG-050.....(pg.16).....	CL-A
SG-75.....(pg.16).....	CL-B
SG-100.....(pg.16).....	CL-C
SG-125.....(pg.16).....	CL-D
SG-150.....(pg.16).....	CL-E
SG-200.....(pg.16).....	CL-F
SG-A.....(pg.17).....	WHB-A
SG-B.....(pg.17).....	WHB-B
SG-C.....(pg.17).....	WHB-C
SG-D.....(pg.17).....	WHB-D
SG-E.....(pg.17).....	WHB-E
SG-F.....(pg.17).....	WHB-F
SS-A.....(pg.17).....	WHB-A
SS-B.....(pg.17).....	WHB-B
SS-C.....(pg.17).....	WHB-C
SS-D.....(pg.17).....	WHB-D
SS-E.....(pg.17).....	WHB-E
SS-F.....(pg.17).....	WHB-F

ZURN LIGHT COMMERCIAL TO MIFAB

TRAP SEAL PRIMERS

ZURN	MIFAB
TP2920.....(pg.5).....	MI-TSP-1
TP2922-PC.....(pg.12).....	MI-700
TP2923-PC.....(pg.12).....	MI-701
TS2900-IP2.....(See MPB-2015).....	TS1002
TS2900-IP3.....(See MPB-2015).....	TS1003
Z1020.....(pg.6,7).....	MI-100
Z1021.....(pg.12).....	MI-750
Z1022-SF.....(pg.5).....	MI-TSP-1
Z1022-IP.....(pg.5).....	MI-TSP-2
Z1022-SFU.....(pg.5).....	MI-TSP-3
Z1023.....(pg.13).....	MI-600-50

WATER HAMMER ARRESTORS

ZURN	MIFAB
WH2950-AA.....(pg.16).....	CL-AA
WH2950-A.....(pg.16).....	CL-A
WH2950-B.....(pg.16).....	CL-B
WH2950-C.....(pg.16).....	CL-C
WH2950-D.....(pg.16).....	CL-D
Z1700-100.....(pg.17).....	WHB-A
Z1700-200.....(pg.17).....	WHB-B
Z1700-300.....(pg.17).....	WHB-C
Z1700-400.....(pg.17).....	WHB-D
Z1700-500.....(pg.17).....	WHB-E
Z1700-600.....(pg.17).....	WHB-F

TERMS AND CONDITIONS

WHOLESALE DISCOUNT:

Contact MIFAB or your local representative for your applicable discount structure.

FREIGHT ALLOWANCE: Ex Works, MIFAB's Chicago, Illinois Factory or Manufacturer Representative's warehouse with full motor freight allowed on shipments of \$1,500.00 Net or more, within the continental U.S.A. or Canada, except Alaska, Hawaii and Puerto Rico. MIFAB reserves the right to choose the carrier and route of shipment. Alaska: Ex Works, Seattle, WA. Hawaii: Freight allowed on shipments of \$1,500.00 or more only when shipped from West Coast, U.S. Puerto Rico: Ex Works, Miami, Florida. There is no allowance for United Parcel Service, Federal Express or Shipment by air service. Full motor freight is allowed on shipments of \$1,500.00 Net or more, within the continental U.S.A. and Canada for any combination of BEECO, Counterline, No Hub Coupling, Trench Drain, Access Door and Trap Seal Primer products. Shipping dates are estimates and time of delivery is not the essence of the sale of the contract. Therefore, under no circumstances will MIFAB have any responsibility on account of any delays in manufacture, transportation, or otherwise. Additional freight services such as construction site delivery, lift gate delivery service, re-consigned freight or notification charges, are not included in full freight allowance terms, and will result in additional freight charges.

QUOTATION TERMS: List Price and discount protected for 30 days from date issued by MIFAB. Orders received within this period must be released for shipment within 30 days from date of purchase order, otherwise, prices will be those that are in effect at the time of shipment.

PAYMENT TERMS: Terms of payment are Net 30 days from the date of the invoice. All pricing in United States currency unless sold in Canada in which case Canadian dollars is the currency used. The Buyer shall pay all sales, consumers, and / or any other applicable taxes. Past due accounts will be subject to a 2% per month service charge from the date of the invoice. If any proceedings be instructed by or against Buyer under any bankruptcy or insolvency law, or if Buyer shall fail to make timely payment on this or any other order, or if, in MIFAB's judgment, Buyer's financial situation justifies such action, MIFAB may, at its election, require payment in advance or cancel the order as to any unshipped item and require payment of its reasonable cancellation charges. If Buyer delays completion of manufacture, MIFAB may elect to require payment according to percentage of completion. Equipment held for Buyer shall be at Buyer's risk and expense. In all cases, regardless of partial payment, title to the Products shall remain with MIFAB until payment for the Products (including any notes given therefore) has been made in full. Should legal action be necessary to enforce payment of an unpaid invoice, the Buyer will assume full responsibility for any court costs and reasonable attorney fees. All orders subject to credit check and approval prior to shipment. Confirmed irrevocable letter of credit or cash in advance of shipment is required for accounts without an established line of credit. Minimum invoice amount is \$100.00. MIFAB reserves the right to apply a minimum order charge to equal \$100.00. MIFAB's Accounting Department must be notified of potential pricing errors within 30 days of the invoice date. Any terms and conditions stated on Buyer's orders which are inconsistent with MIFAB's quotation and Terms and Warranties shall be of no effect.

RETURNED GOODS RESTOCKING CHARGE: Standard product may be returned within a one year period only with written permission from MIFAB. All products in catalog are not considered Standard. Standard product to be determined by MIFAB. Returned goods are subject to a 25% restocking charge, plus cost of reconditioning, if necessary, to make material saleable. Material must be returned to MIFAB freight prepaid only after written permission from MIFAB to accept the returned material. Buyer must provide copy of the original invoice on which the material was charged. The original outgoing freight cost to ship the order will be deducted from the credit. Credit allowance will be in the form of merchandise credit only-not cash credit which must be used within 12 months of the date of issue. The value of a return must total \$100.00 to qualify for credit allowance. Galvanized and acid resistant epoxy coated material will be credited to value of cast iron, and chrome plated at value of nickel bronze. No credit will be allowed for auxiliary tappings, discontinued, or made to order items. Products designated non stock and / or that have been specially made (require a sign off drawing by MIFAB) are not subject to return or cancellation.

LIMITED WARRANTY: MIFAB warrants each product against defects in material and workmanship for a period of one year from the date of original shipment. In the event of such defects within the warranty period, MIFAB will, at its option, replace or recondition the product without charge. This shall constitute the exclusive remedy for breach of warranty, and MIFAB shall not be responsible for any incidental or consequential damages, including, without limitation, damages or other costs resulting from labor charges, delays, vandalism, negligence, fouling caused by foreign material, damage from adverse water conditions, chemicals, or any other circumstances over which MIFAB has no control. This warranty shall be invalidated by any abuse, misuse, misapplication or improper installation of the product.

MIFAB MAKES NO OTHER WARRANTIES EXPRESSED OR IMPLIED AS PROVIDED IN THIS LIMITED WARRANTY.

ILLUSTRATIONS OR TYPICAL INSTALLATIONS: The typical installations for various products in each product section are intended to illustrate the

products and their options. Under no circumstances are they to be construed as recommended installation procedures. Consult local codes and project specifications for proper installation instructions.

ALL SALES SUBJECT TO MIFAB'S TERMS AND WARRANTIES.

NOTE: Prices and terms are subject to change without notice and supersede all previous quotations. The right is reserved to change or modify product design or construction without prior notice and without incurring any obligation to make similar changes and modifications to product previously or subsequently sold. Contact MIFAB for any clarification.

CONTENTS © MIFAB INC. Copyright 2015



www.mifab.com



Trap Seal Primers and Water Hammer Arrestors

LIT-062