

Location: _____



MI-NEUT-NT-5A

**5 GALLON POINT OF USE UNDER SINK
ACID DILUTION / NEUTRALIZATION TANK**

Specification: MIFAB® MI-NEUT-NT-5A, 5 gallon point of use round acid dilution / neutralization tank manufactured out of heavy duty H.D.P.E. material with internal deep seal trap, 1 1/2" no hub side inlet and outlet and bolted, gasketed cover with 8" diameter F.I.P. cleanout in cover.

Function: Ideal for under sink applications.

POINT OF USE: UNDER SINK ACID DILUTION / NEUTRALIZATION TANK

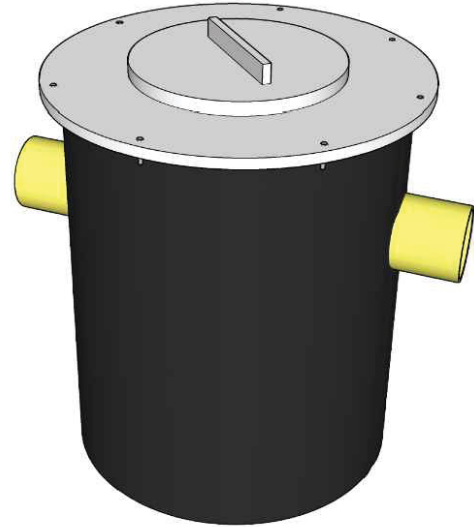
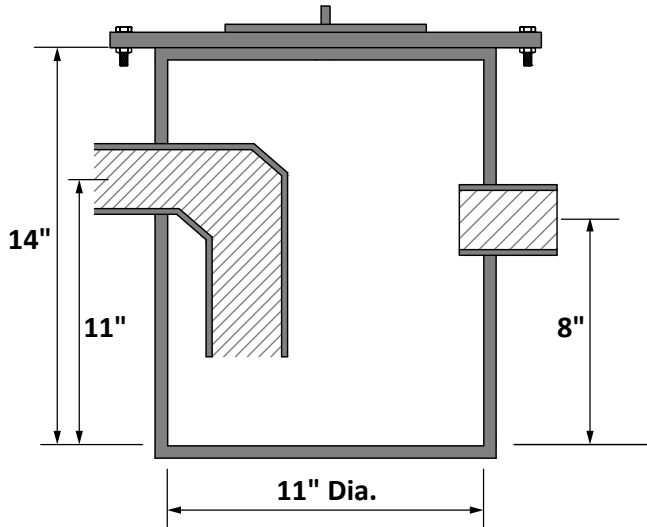

SIDE INLET AND OUTLET WITH BOLTED AND GASKETED COVER.

SUFFIX	OPTIONAL VARIATIONS
-LSC	Limestone media MI-LSC
-SI-200	2" No Hub side inlet and outlet

CALIFORNIA PROPOSITION 65 WARNING. This product contains chemicals known to the State of California to cause cancer and birth defects or other reproductive harm.

Job Name: _____

Page No: _____

Section No: _____

Contractor: _____

Schedule No: _____

Purchase Order No: _____

MIFAB® reserves the right to make changes in material and design without formal notice and obligation.

USA: 1-800-465-2736 www.mifab.com CAN: 1-800-387-3880

2023-05-28