

Location: _____



MI-NEUT-NT-2A

**POINT OF USE UNDER SINK ACID
DILUTION / NEUTRALIZATION TANK**

Specification: MIFAB® MI-NEUT-NT-2A point of use acid dilution / neutralization tank manufactured out of heavy duty H.D.P.E. material with internal deep seal trap, cleanout in lid, 1 1/2" no hub top or side inlet and 1 1/2" side outlet and sealed cover.

Function: Ideal for under sink applications.

POINT OF USE: UNDER SINK ACID DILUTION / NEUTRALIZATION TANK

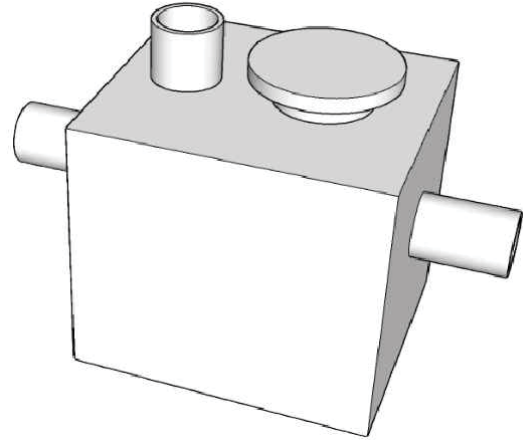
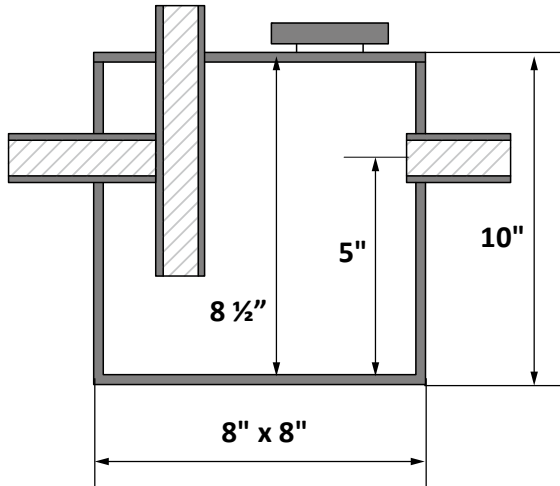

**TOP OR SIDE INLET AND SIDE OUTLET WITH SEALED COVER.
CLEANOUT IN LID**

| SUFFIX | OPTIONAL VARIATIONS |
|---------|---------------------------------|
| -LSC | Limestone media MI-LSC |
| -SI-200 | 2" No Hub side inlet and outlet |
| -TI-200 | 2" No Hub inlet in top of lid |

CALIFORNIA PROPOSITION 65 WARNING. This product contains chemicals known to the State of California to cause cancer and birth defects or other reproductive harm.

Job Name: _____

Page No: _____

Section No: _____

Contractor: _____

Schedule No: _____

Purchase Order No: _____