

Location: \_\_\_\_\_



**MI-NEUT-NT-1**

**POINT OF USE UNDER SINK ACID DILUTION / NEUTRALIZATION TANK**

**Specification:** MIFAB® MI-NEUT-NT-1 point of use 2 gallon acid dilution / neutralization tank manufactured out of heavy duty H.D.P.E. material with internal deep seal trap, 1 1/2" no hub side inlet and outlet and bolted with gasket cover.

**Function:** Ideal for under sink applications.

**POINT OF USE: UNDER SINK ACID DILUTION / NEUTRALIZATION TANK**

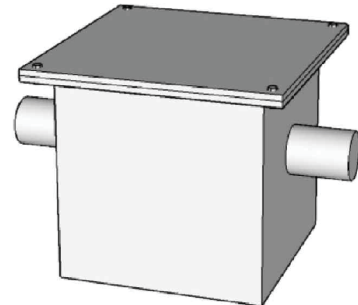
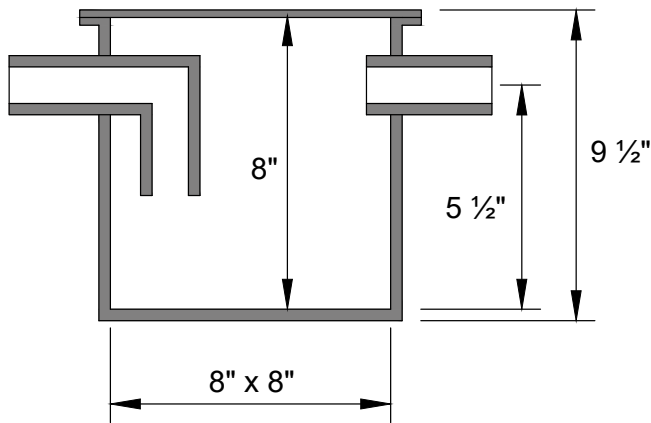

**SIDE INLET AND OUTLET WITH BOLTED AND GASKETED COVER.**

SUFFIX	OPTIONAL VARIATIONS
-LSC	Limestone media MI-LSC
-SI-200	2" No Hub side inlet and outlet

CALIFORNIA PROPOSITION 65 WARNING. This product contains chemicals known to the State of California to cause cancer and birth defects or other reproductive harm.

Job Name: \_\_\_\_\_ Page No: \_\_\_\_\_  
Section No: \_\_\_\_\_ Contractor: \_\_\_\_\_  
Schedule No: \_\_\_\_\_ Purchase Order No: \_\_\_\_\_