

Location: _____



MI-CSD

**COVER SHROUD FOR MI-G-SD(H) SERIES
DRAW-OFF GREASE INTERCEPTORS**

Specification: MIFAB MI-CSD Series fabricated 10 gauge steel, powder epoxy coated cover shroud with 7 gauge, diamond plate, powder epoxy coated lid with recessed pull ring handle and angle support brackets.

Function: Used to provide support for the interceptor and makes the inlet and outlet dimensions adjustable to match drainage piping where necessary. The shroud is secured and suspended in the slab by its anchoring flanges. The interceptor is easily accessible for cleaning and inspection simply by removing the cover that sits flush with the floor.

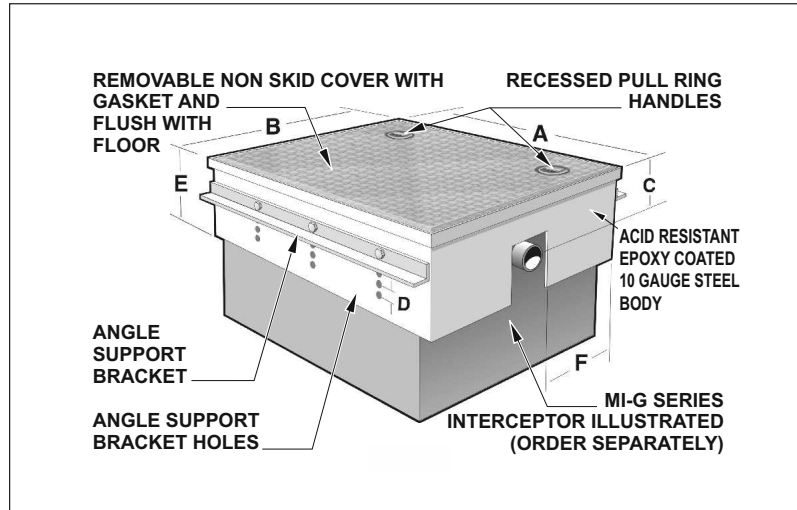

PART NO.	USE WITH INTERCEPTOR	A IN	B IN	C IN	D IN	E IN	F IN
MI-CSD-7	MI-G-SD(H)-1	32.75	18.75	6	1.00	11.75	5.50
MI-CSD-10	MI-G-SD(H)-2	36.75	20.75	6	1.00	11.75	6.25
MI-CSD-15	MI-G-SD(H)-3	38.75	20.75	6	1.00	11.75	6.25
MI-CSD-20	MI-G-SD(H)-4	38.75	20.75	6	1.00	14.75	6.25
MI-CSD-25	MI-G-SD(H)-5	42.75	23.75	6	1.25	14.75	7.00
MI-CSD-35	MI-G-SD(H)-6	46.25	28.75	8	1.25	14.75	8.75
MI-CSD-50	MI-G-SD(H)-7	46.25	28.75	8	1.25	14.75	8.75
MI-CSD-75*	MI-G-SD(H)-8	47.00	33.00	8	1.25	14.75	9.50

NOTE: *75 & 100 GPM require 2 lids.

SUFFIX	OPTIONAL VARIATIONS
-AL	Aluminum lid
-SS	Fabricated Type 304 Stainless Steel cover shroud and lid

CALIFORNIA PROPOSITION 65 WARNING. This product contains chemicals known to the State of California to cause cancer and birth defects or other reproductive harm.

Job Name: _____ Page No: _____
 Section No: _____ Contractor: _____
 Schedule No: _____ Purchase Order No: _____