

Location: \_\_\_\_\_



**MC-40D**

**FIXTURE CARRIER WITH  
BACK TO BACK EXPOSED ARMS**

**Specification:** MIFAB® Series MC-40D floor mounted exposed arm lavatory carrier with back to back white, lacquered, adjustable, cast iron exposed support arms. Complete with back to back lacquered cast iron invertible and adjustable arm supporting brackets, alignment rod, two lacquered 2" x 1" x 1/8" thick structural steel uprights with 3" x 4 1/2" welded steel feet and mounting hardware.

**Function:** Used to support back to back heavy duty lavatories that are independent of the wall. Heavy duty cast iron support arms provide extra support for the fixtures that are unavailable drilled for concealed arms such as semi-counter top lavatories.

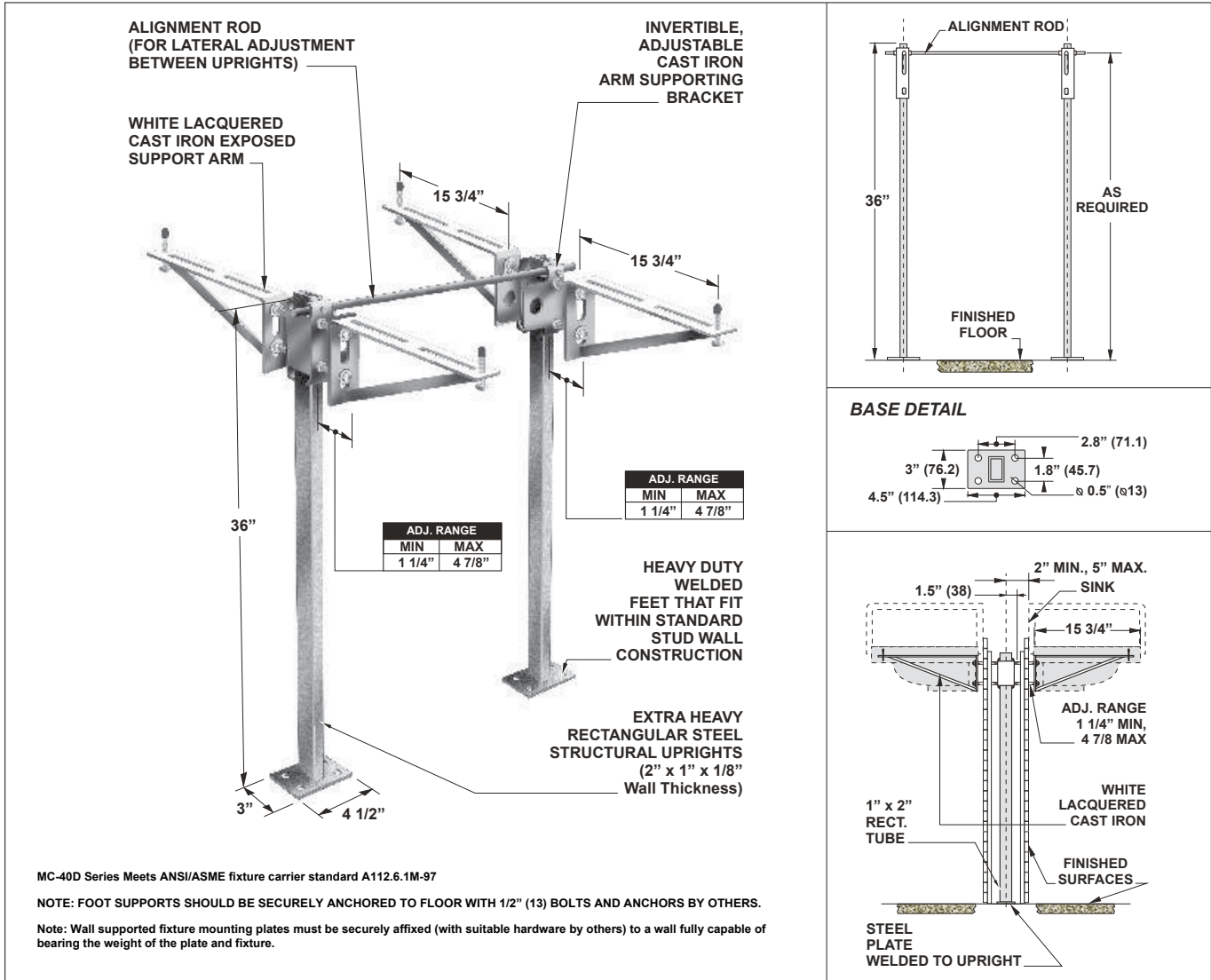

SUFFIX	OPTIONAL VARIATIONS
-A	Stud length over 8" (specify)
-BA	Minimum 51% material cost made in the USA
-F	Bar support valve plate
-G	Wall support plate
-PA	Pennsylvania Steel Act compliant product
-PFAB	Prefabricated carrier
-Z	Higher uprights (over 36")
-14	Vandal proof finish trim
-32	Foot pedal mounting plate
-88	3/8" threaded eye bolts for cast iron lavs (H-1028)

CALIFORNIA PROPOSITION 65 WARNING. This product contains chemicals known to the State of California to cause cancer and birth defects or other reproductive harm.

Job Name: \_\_\_\_\_ Page No: \_\_\_\_\_

Section No: \_\_\_\_\_ Contractor: \_\_\_\_\_

Schedule No: \_\_\_\_\_ Purchase Order No: \_\_\_\_\_