

Location: _____



MC-13D

**DOUBLE, VERTICAL, ADJUSTABLE
WATER CLOSET CARRIER WITH SIDE INLETS**

Specification: MIFAB® Series MC-13D double, vertical, adjustable water closet carrier with lacquered cast iron fitting, left, right or both (specify) 4" (102) side inlets, 4" (102) no hub waste, 2" (51) no hub vent connection, lacquered cast iron gasketed adjustable faceplates, universal floor mounted cast iron foot supports, adjustable 8" tapered thread ABS nipples with integral test caps, neoprene bowl gaskets, hardware, threaded rod protectors and polished chrome plated finishing cap nuts.

Function: Used when one or two side inlets and through the slab pipe connection is required. Typical for back to back water closets installed on a common stack to receive waste from the horizontal piping of MC-10 horizontal fittings or to receive waste from other plumbing fixtures with waste lines roughed in above the floor slab. Adjustable fitting and faceplate design permits installer to set the water closets to the desired height from the finished floor, relative to the position of the vertical carrier fitting within the stack system and the position of the horizontal waste piping from the horizontal carriers within the battery system. Typical for off the floor plumbing fixtures that are wall mounted and have no contact with the finished floor. The closet carrier is completely concealed within the wall and supports the load of the fixture through a faceplate and foot support system that is anchored to the floor. Sanitation underneath the fixture is more efficiently and economically maintained when installed off of the floor compared to floor mounted. **Note:** 11" (279) minimum space required between front of foot and rear of anchor support. 8 1/2" (216) minimum in wall space required between back of rear anchor support and back of in wall foot supports.

Note: 14 1/2" (368) minimum space required between front of foot supports. 9" (229) minimum in wall space required between back of in wall foot supports.

Note: Foot supports and faceplate are assembled at the factory before shipment in the typical siphon jet water closet configuration and are reversible for the blowout water closet design.

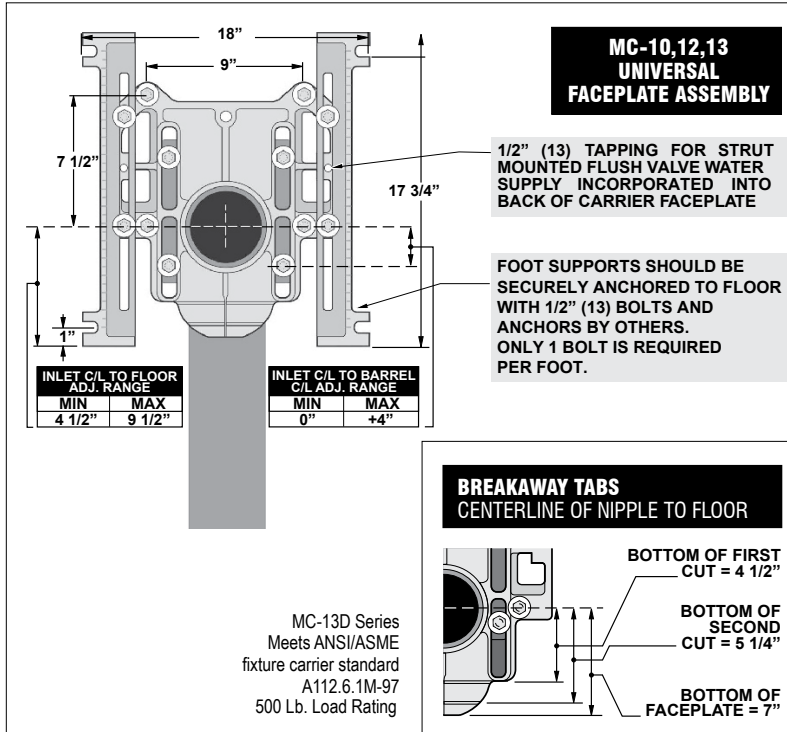

Note: 8" tapered thread ABS nipple shipped standard with MC-13 Series carriers. The universal faceplate assembly accepts all nipple variations, rolling thread (-OR), cast iron (-CI) and tapered thread ABS with adjustable horn (-AH).

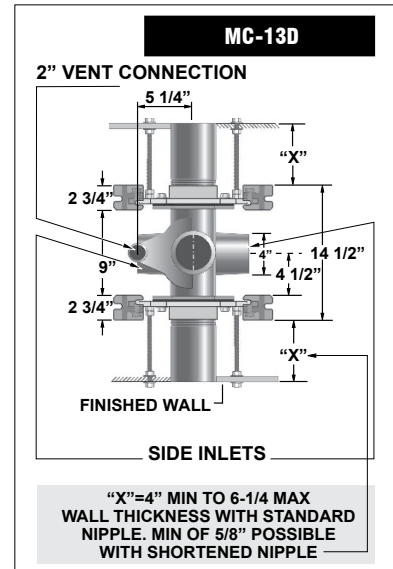

SUFFIX	OPTIONAL VARIATIONS
-AH8	8" ABS nipple with adjustable horn
-AH12	12" ABS nipple with adjustable horn
-BA	Buy American Act compliant product
-CI-4	4" rolling thread cast iron nipple
-CI-6	6" rolling thread cast iron nipple
-CI-8	8" rolling thread cast iron nipple
-CI-12	12" rolling thread cast iron nipple
-CI-24	24" rolling thread cast iron nipple
-FM	Floor mount, back outlet fixture support
-HD-750	750 lb. rated heavy duty
-HDX	1,000 lb. rated extra heavy duty
-HS	Hub and spigot connection
-L	Left hand fitting
-OR8	8" rolling thread ABS nipple
-OR12	12" rolling thread ABS nipple
-PA	Pennsylvania Steel Act compliant product

-PFAB	Prefabricated carrier
-R	Right hand fitting
-01	Neoprene bowl gasket
-1	Finishing / Tiling frame
-2	Two side inlets (4")
-3	Rear anchor support (Standard)
-10	Auxiliary support, recommended with nipple lengths over 12"
-12	12" tapered thread ABS nipple
-13	All galvanized
-14	Vandal proof finish trim
-17	Test plug for custom cast iron nipples
-19	Nipple wrench
-20	Flush valve support
-22	Less fitting
-25	2" Auxiliary inlet, right side
-26	2" Auxiliary inlet, left side
-31	Two 2" Auxiliary inlets

CALIFORNIA PROPOSITION 65 WARNING. This product contains chemicals known to the State of California to cause cancer and birth defects or other reproductive harm.

Job Name: _____

Page No: _____

Section No: _____

Contractor: _____

Schedule No: _____

Purchase Order No: _____