

Location: \_\_\_\_\_



**MC-10-EXT**

**HORIZONTAL ADJUSTABLE WATER CLOSET CARRIER FOR ADA HEIGHT WATER CLOSETS IN MIDDLE OF BATTERY (FOR SIPHON JET AND BLOWOUT TOILETS)**

**Specification:** MIFAB® Series MC-10-EXT (Specify L for left or R for right design) single, horizontal, adjustable, high rough-in water closet carrier with lacquered cast iron fitting, 4" (102) no hub waste, 2" (51) no hub vent connection, lacquered cast iron gasketed adjustable faceplate, universal floor mounted cast iron foot supports, adjustable 8" tapered thread ABS nipple with integral test cap, neoprene bowl gasket, hardware, threaded rod protectors, polished chrome plated finishing cap nuts and rear anchor tie down support.

**Function:** Used in the middle of horizontal batteries where the water closet must be elevated 3" (76) higher than the normal roughin height to accommodate fixtures for wheelchair users. The elevated inlet flange permits the water closet to be installed at any position in the battery. Typical with off the floor plumbing fixtures that are wall mounted and have no contact with the finished floor. The closet carrier is completely concealed within the wall and supports the load of the fixture through a faceplate and foot support system that is anchored to the floor. Sanitation underneath the fixture is more efficiently and economically maintained when installed off of the floor compared to floor mounted.

**Note:** 10 1/2" (267) minimum space required between front of foot and rear of anchor support. 8" (203) minimum in wall space required between back of rear anchor support and back of in wall foot supports.

**Note:** Foot supports and faceplate are assembled at the factory before shipment in the typical siphon jet water closet configuration and are reversible for the blowout water closet design.

**Note:** 8" tapered thread ABS nipple shipped standard with MC-10 Series carriers. The universal faceplate assembly accepts all nipple variations, rolling thread (-OR), cast iron (-CI) and tapered thread ABS with adjustable horn (-AH). (See page 224).

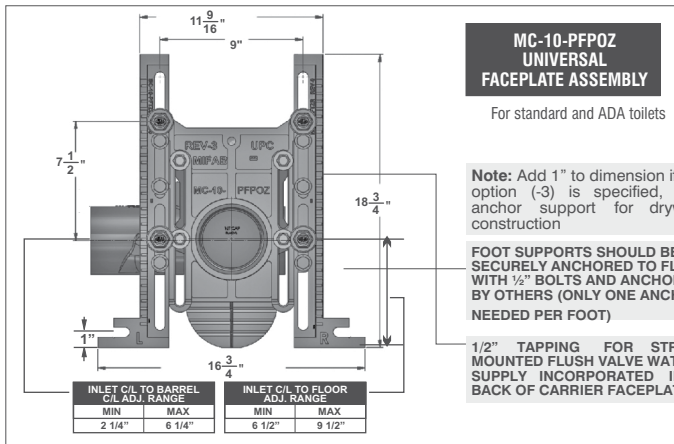

\*MC-10-EXT is tested to support a 500 lb. load with the rear anchor support.

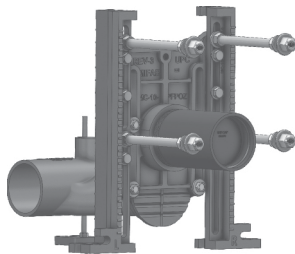
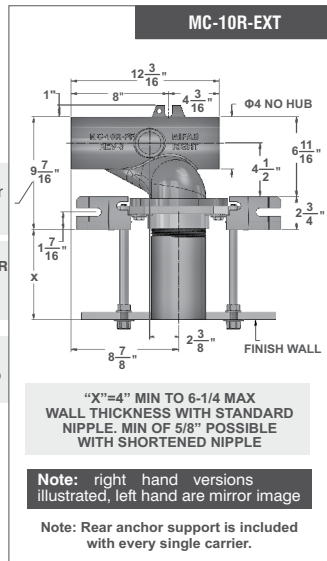
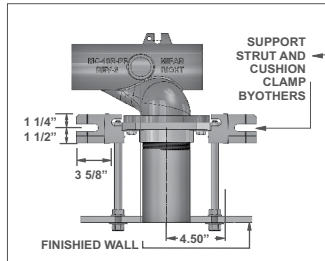
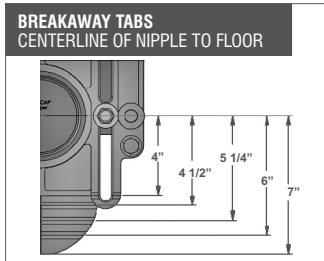

MODEL NO.	DESCRIPTION	WEIGHT (Lbs.)
MC-10L-EXT	Single left hand	66.00
MC-10R-EXT	Single right hand	66.00
MC-10D-EXT	Double - back to back	117.00
-HS	Hub and Spigot connection (single) Hub and Spigot connection (double)	

**MC-10-EXT Series Meets ANSI/ASME fixture carrier standard A112.6.1M-97 500Lb. Load Rating**

SUFFIX	OPTIONAL VARIATIONS
-01	Neoprene bowl gasket (MC-10-PBG)
-1	Finishing / Tiling Frame (MC-10-1-PTFK)
-3	Rear anchor support (MC-10-3-PRSFK)
-10	Auxiliary support, recommended with nipple lengths over 12"(MC-10-AFS)
-12	12" tapered thread ABS nipple* (MC-10-PN12-31)
-13	All galvanized
-14	Vandal proof finish trim (MC-10-PFH-14)
-17	Test plug for custom cast iron nipples
-19	Nipple wrench (MC-10-PCW)
-20	Flush valve support (MC-10-FVS)
-22	Less fitting
-AH8	8" ABS nipple with adjustable horn (MC-10-PN8AH-31)
-AH12*	12" ABS nipple with adjustable horn* (MC-10-PN12AH-31)

-ASY	Prefabricated carriers
-CI-4	4" rolling thread cast iron nipple (MC-10-PN4R-50)
-CI-6	6" rolling thread cast iron nipple (MC-10-PN6R-50)
-CI-8	8" rolling thread cast iron nipple (MC-10-PN8R-50)
-CI-12*	12" rolling thread cast iron nipple* (MC-10-PN12R-50)
-CI-24	24" rolling thread cast iron nipple (MC-10-PN24R-50)
-FM	Floor mount back outlet fixture support
-HD-750	750 lb. rated heavy duty
-HDX	1,000 Lb. rated extra heavy duty
-OR8	8" rolling thread ABS nipple (MC-10-PN8R-31)
-OR12*	12" rolling thread ABS nipple (MC-10-PN12R-31)

\* H-1167-KA-14 ( Threaded rods for 12" nipples 5/8" x 14")

CALIFORNIA PROPOSITION 65 WARNING. This product contains chemicals known to the State of California to cause cancer and birth defects or other reproductive harm.

Job Name: \_\_\_\_\_ Page No: \_\_\_\_\_  
 Section No: \_\_\_\_\_ Contractor: \_\_\_\_\_  
 Schedule No: \_\_\_\_\_ Purchase Order No: \_\_\_\_\_