

# LID INSTALLATION - BIG MAX & SUPER MAX

## LID INSTALLATION DETAILS

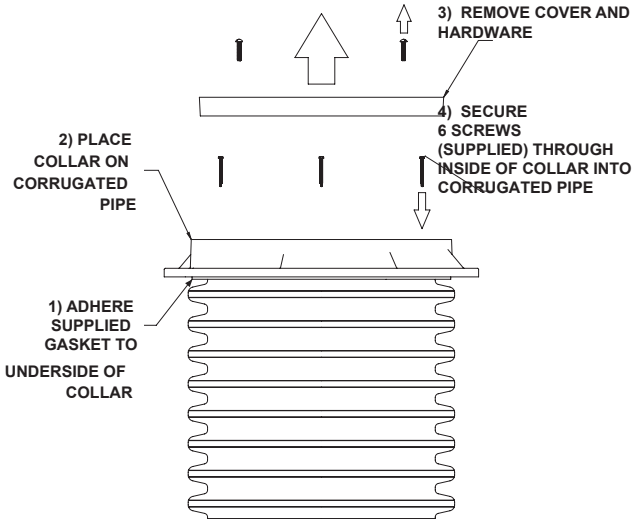

## ANCHOR FLANGE AND MEMBRANE CLAMP DETAILS

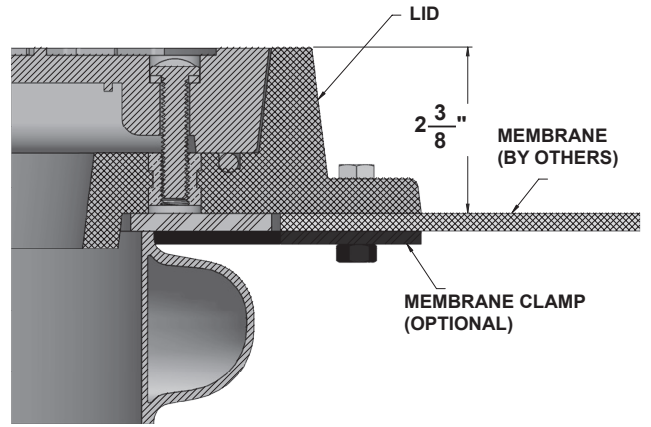

## PLAN VIEW OF COLLAR

DRILLING POSITION FOR SCREWS WILL BE FOUND UNDER LID (6 HOLES)

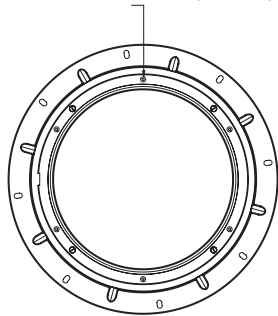

## CROSS SECTION VIEW OF STEP 4

