

Location: _____



LAVATORIES CLOSET CARRIERS

LAVATORIES CARRIER DIMENSIONAL DATA

HORIZONTAL AND VERTICAL ADJUSTABLE / FIXED LAVATORIES CLOSET CARRIER MINIMUM SPACE REQUIREMENTS

Dimensions shown are minimum assuming carrier face plate and foot are built in wall and minimum length shortened coupling is used.

Dimensions shown are minimum assuming carrier fitting, face plate foot and rear anchor foot are located in pipe chase.

HANGER PLATE CARRIERS

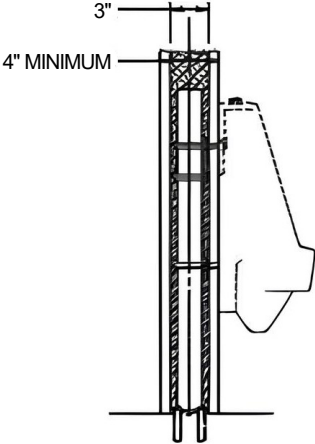
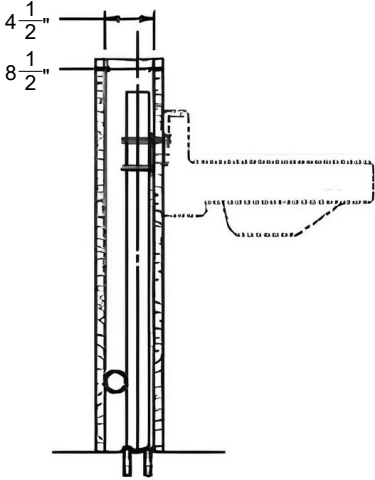
IN WALL	IN PIPE CHASE
 <p style="text-align: center;">MC-31/32</p>	 <p style="text-align: center;">MC-31/32</p>

ARM LAVATORY CARRIERS

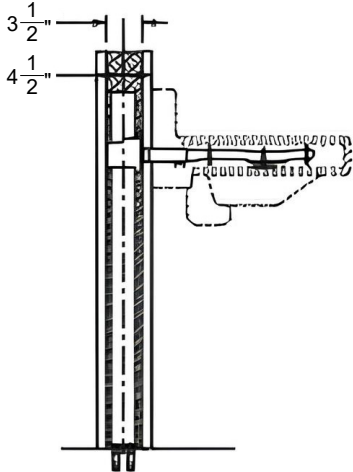
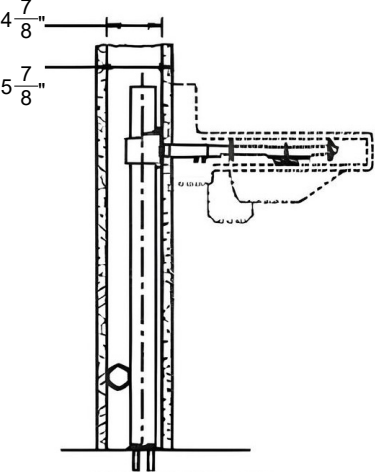
IN WALL	IN PIPE CHASE
 <p style="text-align: center;">MC-41/42</p>	 <p style="text-align: center;">MC-40/41/42</p>

CALIFORNIA PROPOSITION 65 WARNING. This product contains chemicals known to the State of California to cause cancer and birth defects or other reproductive harm.

Job Name: _____

Page No: _____

Section No: _____

Contractor: _____

Schedule No: _____

Purchase Order No: _____