

Location: \_\_\_\_\_



**HY-1600-3-RB**

**HYDRANT BOX**

**Specification:** MIFAB® HY-1600-3-RB Series encased stainless steel hydrant box for 6" diameter core holes in tilt up construction with screwdriver operated cam latch.

**Function:** Designed to be installed into a 6" diameter core hole in tilt up construction. For use with the MIFAB MHY-10, 15, 16, 30 and 50 wall hydrants.

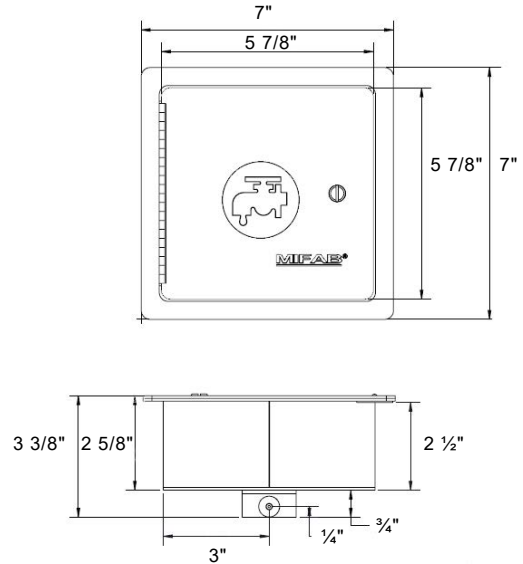

MODEL	DESCRIPTION	WEIGHT
HY-1600-3-RB	Satin Finish, Stainless Steel Box	3.25 lbs.

### OPTIONAL VARIATIONS

-K Cylinder lock key

CALIFORNIA PROPOSITION 65 WARNING. This product contains chemicals known to the State of California to cause cancer and birth defects or other reproductive harm.

Job Name: \_\_\_\_\_ Page No: \_\_\_\_\_  
Section No: \_\_\_\_\_ Contractor: \_\_\_\_\_  
Schedule No: \_\_\_\_\_ Purchase Order No: \_\_\_\_\_