

# Testing Procedures & Trouble Shooting Guide

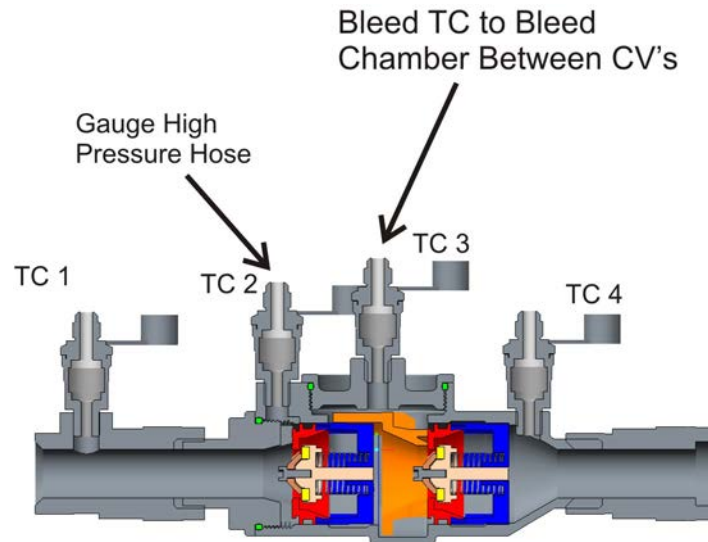

Double Check Backflow Preventer  
(1/2" – 2")

## First Check Valve Test



- 1) Bleed all test cocks.
- 2) Attach high side hose with bleed off valve to TC2. Then, bleed TC2 through the high side needle valve.
- 3) Open TC3 and let the water run out, then close TC3.
- 4) Close SOV2. Hold the test gauge such that the center of the test gauge is at the same height as the top of TC3. Close SOV1.
- 5) Slowly open TC3. Once the water stops running, record the pressure indicated by the test kit. This is the pressure differential across CV1.

## Second Check Valve Test

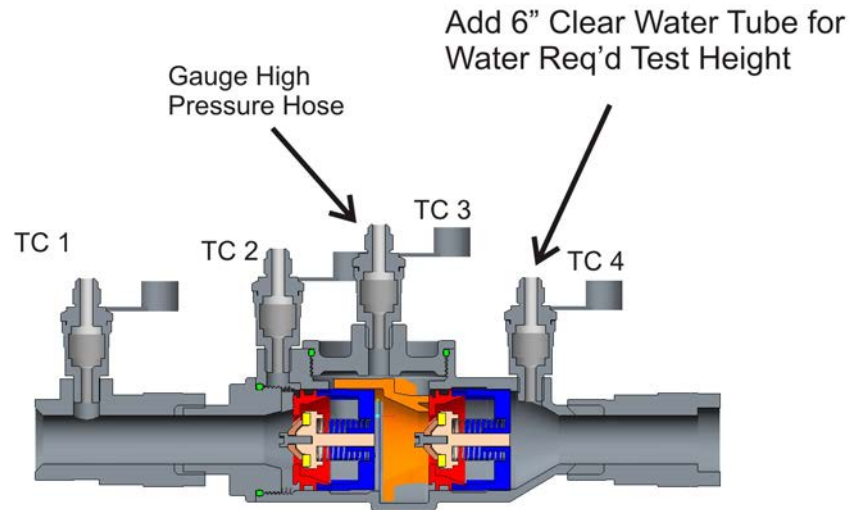

- 1) Attach high side hose with bleed off valve to TC3.
- 2) Attach a 6" clear tube TC4 so that it is the highest point of the check valve body.
- 3) Bleed TC3 through the high side needle valve. Close the needle valve and open TC4 to let the water run out.
- 4) Hold the test gauge such that the center of the test gauge is at the same height as the top of the water in the clear tube attached to TC4. Once TC4 and the tube are filled, close TC4.
- 5) Close the first shut off valve (SOV1) on the FDC.
- 6) Open TC4 slightly and let water flow out of the tube.
- 7) Once the water stops running, record the pressure from the test kit, this is the pressure differential across the second check valve.

# BEECO FRIENDLY DOUBLE CHECK (1/2" - 2")

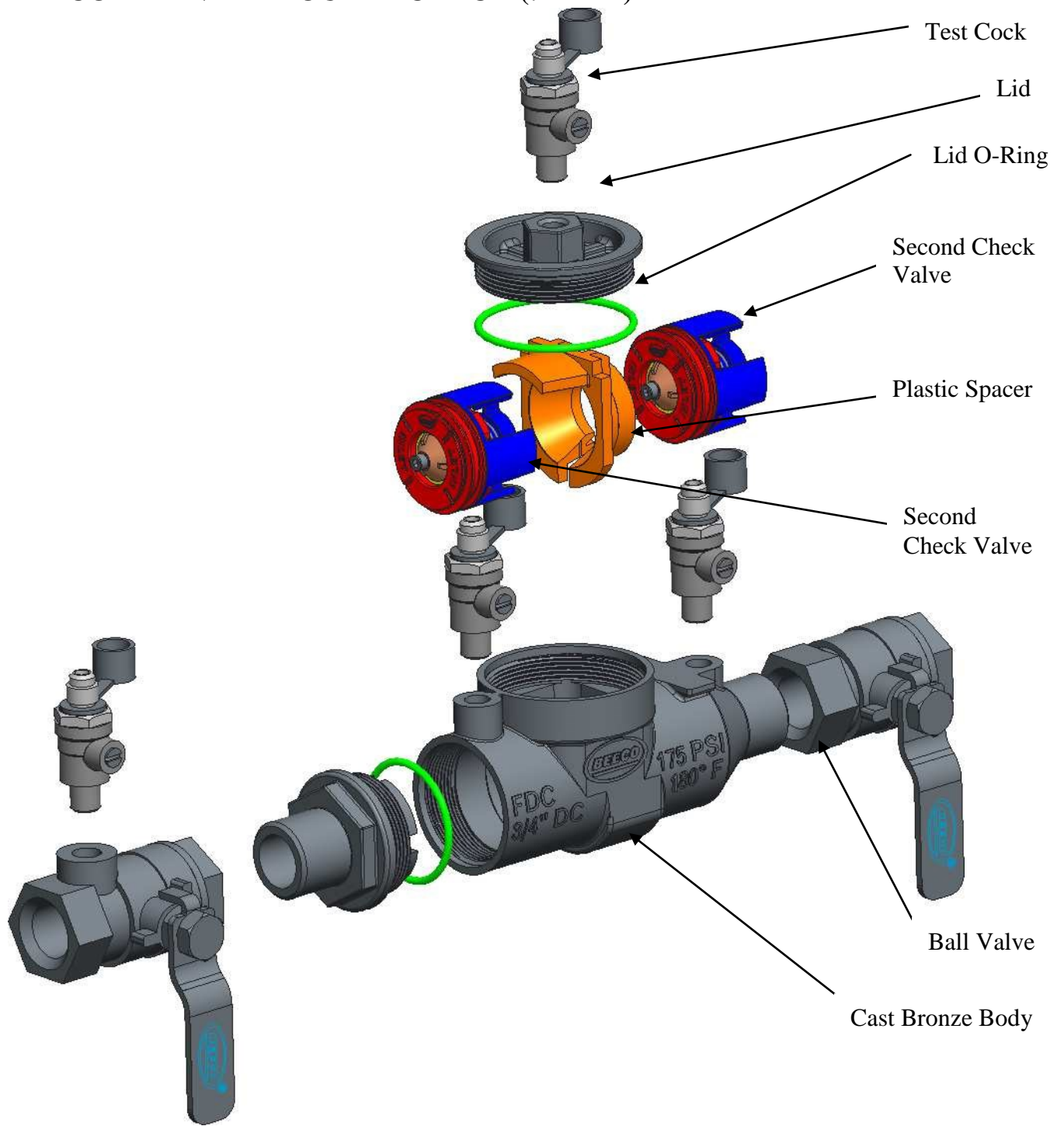

**BEECO CHECK VALVE (1/2" – 2")**

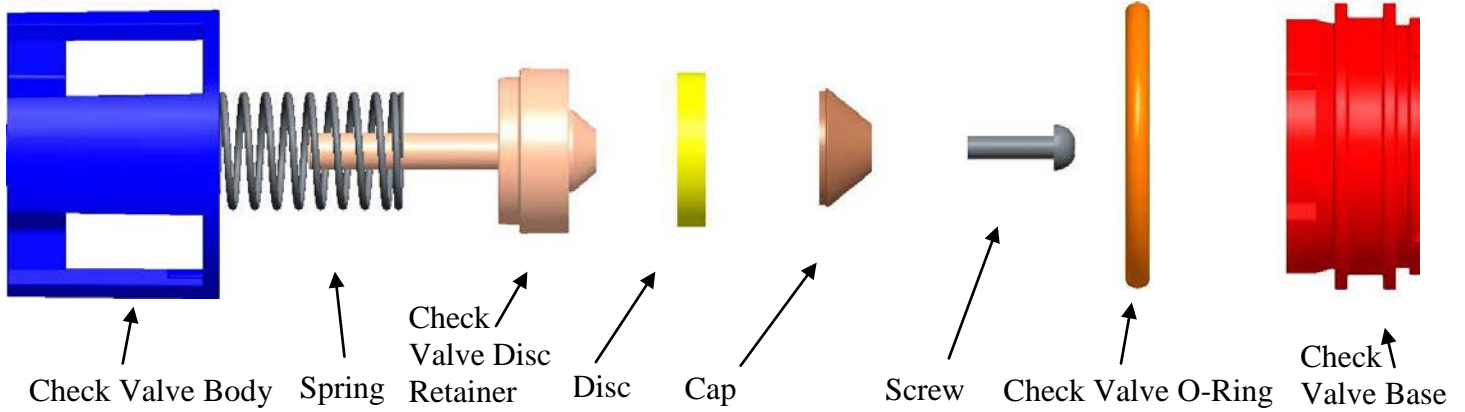

# Trouble Shooting Guide

Problem	Probable Causes
No flow	Device installed backwards.
	Upstream or downstream gate valves not open.
	Clogged strainer or clogged device.
Low flow	Low supply pressure.
	Pressure drop through the device.
	Device's gate valves not opened completely.
Leaking Check Valves	Debris on seat area or seal
	Damaged seat area
	Damaged seal