

Location: _____



FD240

HEAVY DUTY FLOOR DRAIN

Specification: MIFAB Series FD240 lacquered ductile iron area drain with 1/2" (13) thick, 6 1/2" (165) diameter heavy duty ductile iron grate with stainless steel screws. Recommended for use in vehicular traffic areas.

Function: Used in warehouses, mechanical rooms and other non-membrane finished areas. Round strainer is used with all types of finished floors. Shallow depth body is ideal for shallow pour applications.

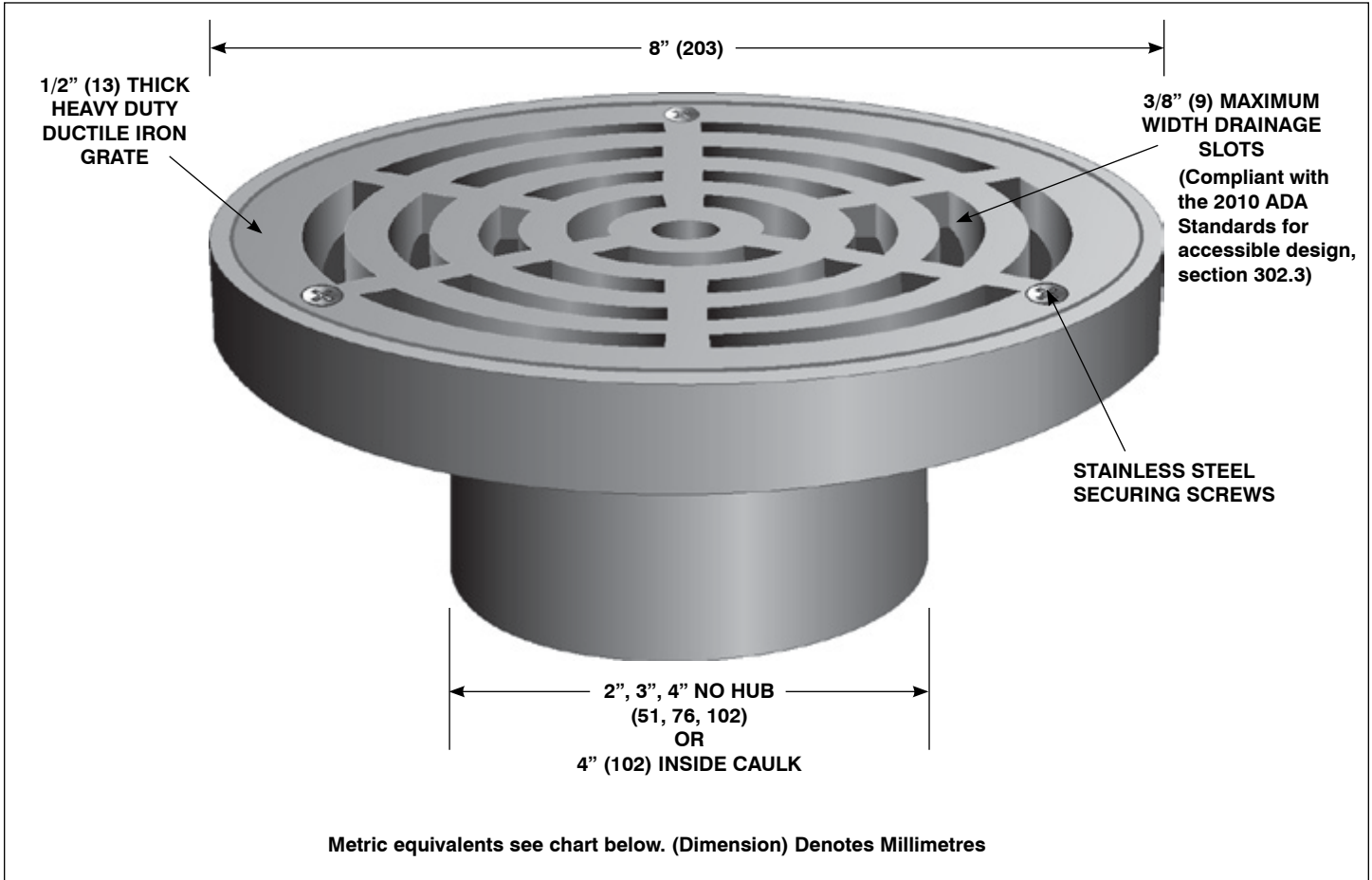

Model Number	Product Description	A IN	B IN	C IN	D IN	ANSI/ASME Load Rating	Grate Thickness	Free Area	Weight Lbs.
FD242-4	2" (50) No Hub C.I. Body	2" (50)	6 1/2" (165)	3" (75)	2 3/8" (60)	Heavy Duty	2" (50)	2 5/16" (59)	4 lbs.
FD243-4	3" (75) No Hub C.I. Body	3" (75)	6 1/2" (165)	3" (75)	3 3/8" (86)	Heavy Duty	3" (75)	2 5/16" (59)	4 lbs.
FD244-4	4" (100) No Hub C.I. Body	4" (100)	6 1/2" (165)	3" (75)	4 3/8" (111)	Heavy Duty	4" (100)	2 5/16" (59)	4 lbs.

SUFFIX OPTIONAL VARIATIONS

- 1 Nickel Bronze Grate
- 4 Ductile Iron Grate
- 30 PVC Socket Connection Body
- 31 ABS Socket Connection Body

Job Name: _____ Page No: _____
 Section No: _____ Contract: _____
 Schedule No: _____ Purchase Order No: _____