

Location:



FD212TC-S5-49

SHOWER/FLOOR DRAIN WITH SQUARE TOP

Specification: MIFAB® Series FD212TC-S5-49 lacquered cast iron floor drain with anchor flange, cast iron clamp ring with weepholes for waterproofing membrane, and polished 5" x 5" square chrome plated strainer.

Function: Used in showers, kitchens, restrooms and other membrane finished areas. Round, adjustable strainer is used with all types of poured finished floors. Membrane clamp is provided to secure the waterproofing membrane.

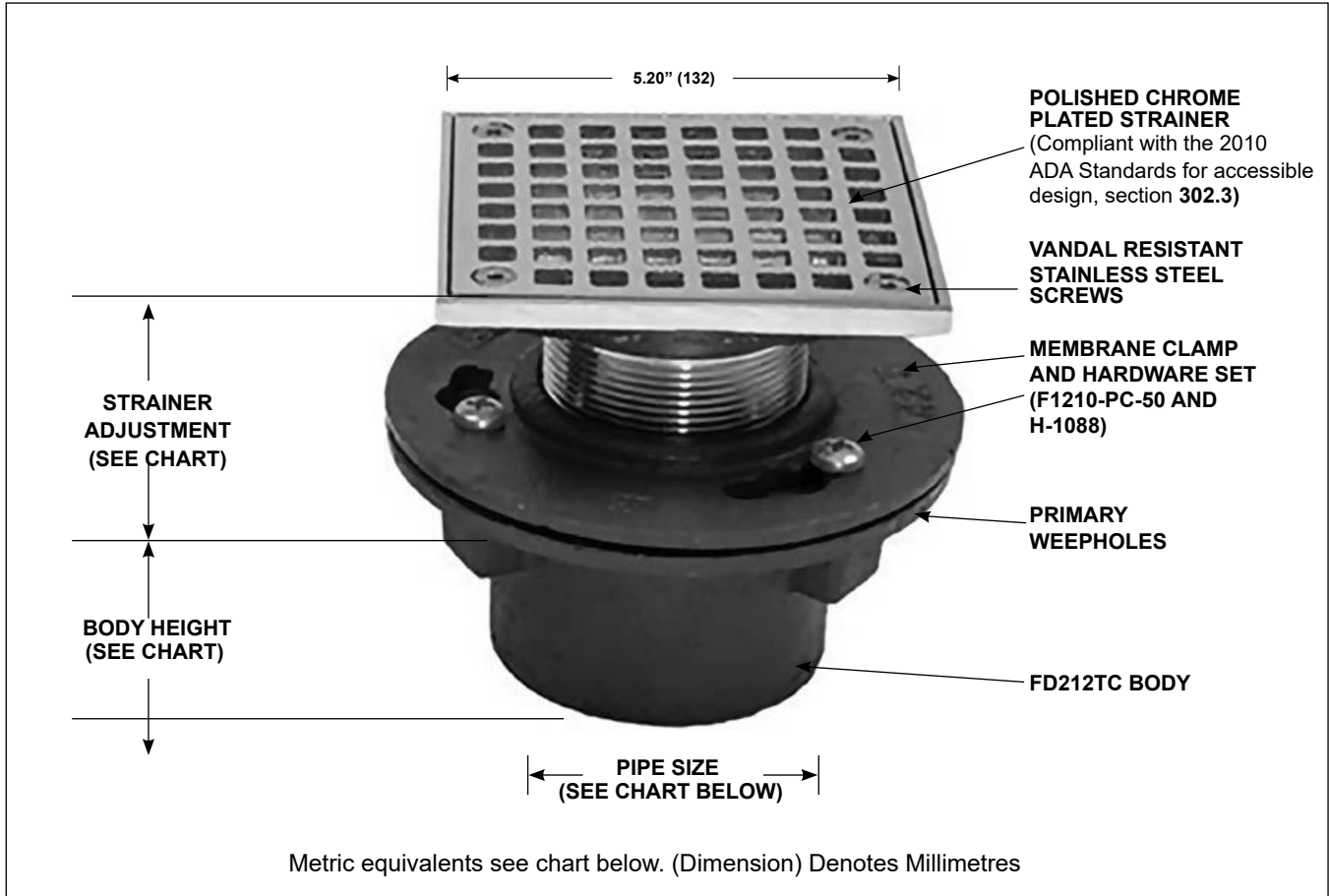

MODEL #	STRAINER SIZE	STRAINER ADJUSTMENT			ANSI / ASME RATING		BODY HEIGHT THREADED (T)	WEIGHT LBS.
		PIPE SIZE	MIN.	MAX.	FREE AREA	LOAD RATING		
FD212TC-S5-49	5" (125) x 5" (125)	2" (52) I.P.S.	1 3/8" (35)	2 1/4" (63)	9.0 in ²	Up to 2,000 lbs.	2 5/16" (59) I.P.S.	5 lbs.

Job Name:

Section No:

Schedule No:

Page No:

Contract:

Purchase Order No: