

Location: \_\_\_\_\_



**F320**

**9" ROUND HEELPROOF ADJUSTABLE AREA DRAIN**

**Specification:** MIFAB Series F320 floor drain with anchor flange, primary and secondary weepholes, and standard 1" (25) thick, 9" (229) round, heelproof, adjustable ductile iron tractor grate.

**Function:** Used in warehouses, mechanical rooms, parking garages and other membrane finished areas. 9" Round, adjustable tractor grate is used with all types of poured finished floors.

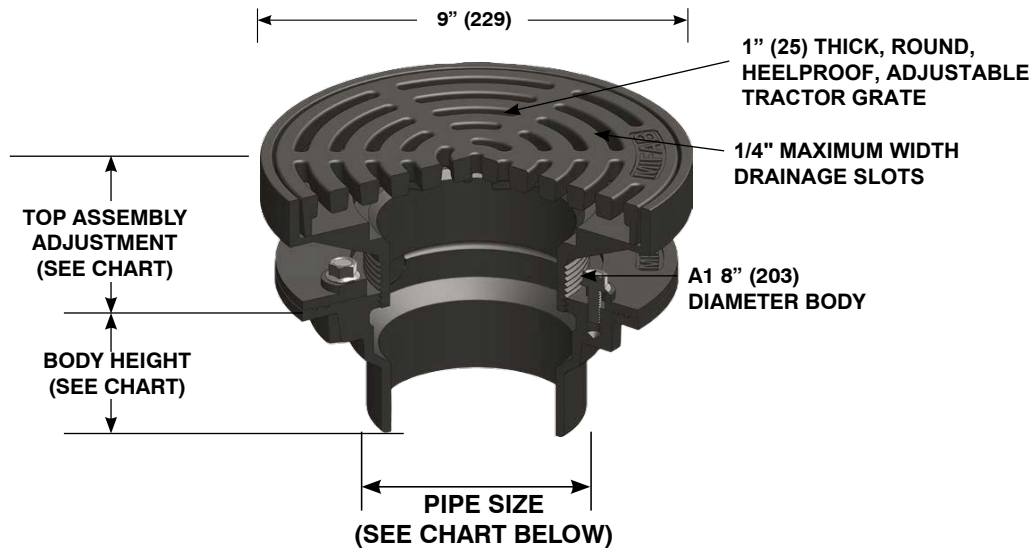

Metric equivalents see chart below. (Dimension) Denotes Millimetres

Note: Illustrated with -C optional membrane clamp

STRAINER DIAMETER	STRAINER ADJUSTMENT		ANSI/ASME RATING		PIPE SIZE	BODY HEIGHT		
			FREE AREA	LOAD RATING		NO HUB (STANDARD)	PUSH ON (P)	PVC/ABS (-30)/(-31)
	MIN	MAX		D.I. (-4)				
9" (229)	1 5/8" (41)	2 5/8" (67)	11 in <sup>2</sup> (7096 <sup>2</sup> )	OVER	2" (51)	4" (102)	4 3/8" (111)	4 3/8" (111)
				10,000 LBS.	3" (76)	4" (102)	4 3/8" (111)	4 3/8" (111)
					4" (102)	4" (102)	4 3/8" (111)	4 3/8" (111)

**SUFFIX OPTIONAL VARIATIONS**

- 6 Vandal proof
- C Membrane clamp

Job Name: \_\_\_\_\_  
 Section No: \_\_\_\_\_  
 Schedule No: \_\_\_\_\_

Page No: \_\_\_\_\_  
 Contract: \_\_\_\_\_  
 Purchase Order No: \_\_\_\_\_