

Location: \_\_\_\_\_



**F300**

**7" ROUND HEELPROOF ADJUSTABLE AREA DRAIN**

**Specification:** MIFAB Series F300 floor drain with anchor flange, primary and secondary weepholes, and standard 1" (25) thick, 7" (178) round, heelproof, adjustable ductile iron tractor grate.

**Function:** Used in warehouses, mechanical rooms, parking garages and other membrane finished areas. 7" Round, adjustable tractor grate is used with all types of poured finished floors.

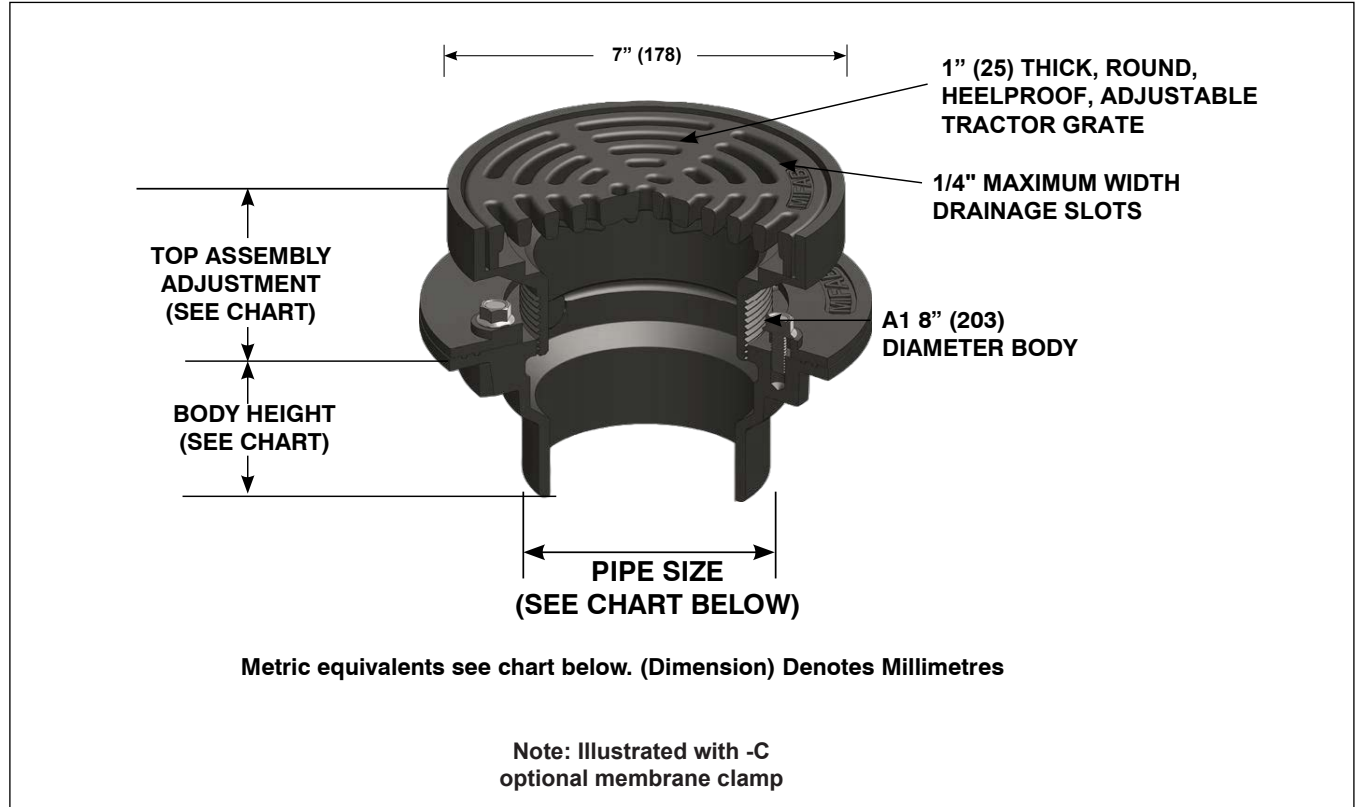

STRAINER DIAMETER	STRAINER ADJUSTMENT		ANSI/ASME RATING		PIPE SIZE	BODY HEIGHT		
			FREE AREA	LOAD RATING		NO HUB (STANDARD)	PUSH ON (P)	PVC/ABS (-30)/(-31)
	MIN	MAX		D.I. (-4)				
7" (178)	1 5/8" (41)	2 5/8" (67)	11 in <sup>2</sup> (7096 <sup>2</sup> )	OVER	2" (51)	4" (102)	4 3/8" (111)	4 3/8" (111)
				10,000 LBS.	3" (76)	4" (102)	4 3/8" (111)	4 3/8" (111)
					4" (102)	4" (102)	4 3/8" (111)	4 3/8" (111)

**SUFFIX OPTIONAL VARIATIONS**

- 6 Vandal proof
- C Membrane clamp

Job Name: _____	Page No: _____
Section No: _____	Contract: _____
Schedule No: _____	Purchase Order No: _____