

Location: _____



F220-S

SQUARE ADJUSTABLE FLOOR DRAIN

Specification: MIFAB Series F220-S floor drain standard reinforced, (specify size) square nickel bronze strainer.

Function: Used in showers, kitchens, restrooms and other non-membrane finished areas. Square adjustable strainer is used for floors that are finished of material or straight line patterns.

F220-30-S5-1

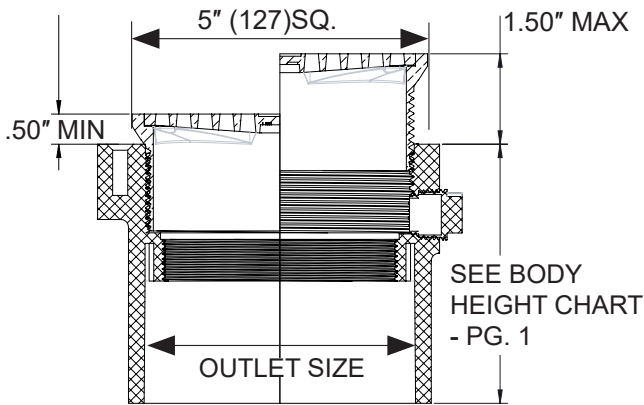

F220P-S5-1

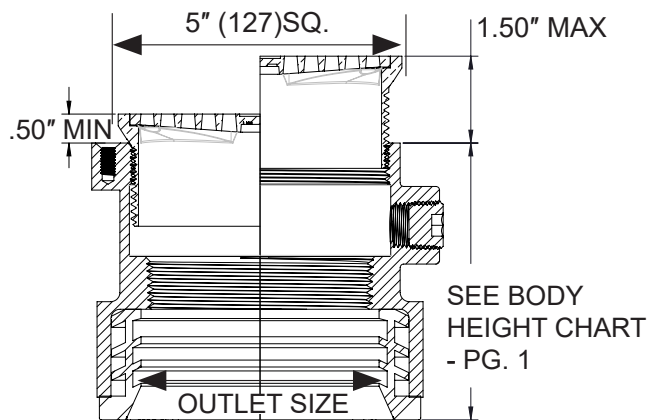

| STRAINER DIAMETER | STRAINER ADJUSTMENT | | ANSI/ASME RATING | | PIPE SIZE | BODY HEIGHT | | |
|------------------------|---------------------|--------------|--|---------------------|-----------|-------------------|--------------|---------------------|
| | | | FREE AREA | LOAD RATING | | NO HUB (STANDARD) | PUSH ON (P) | PVC/ABS (-30)/(-31) |
| | MIN | MAX | | N.B. (-1) | | | | |
| 5" x 5" (127 x 127) | 5/8" (15) | 1 9/16" (40) | 9 in ² (5800 ²) | UP TO 2,000 LBS. | 2" (51) | 4" (102) | 4 3/8" (111) | 4 3/8" (111) |
| 6" x 6" | 7/8" (22) | 1 9/16" (40) | 12 in ² (7700 ²) | | 3" (76) | 4" (102) | 4 3/8" (111) | 4 3/8" (111) |
| (152 x 152) | | | | | 4" (102) | 4" (102) | 4 3/8" (111) | 4 3/8" (111) |

| OPTIONAL VARIATIONS SUFFIX | DESCRIPTION |
|----------------------------|-----------------------------------|
| -5 | Sediment Bucket (A1-PB) |
| -6 | Vandal Proof (H-1039A - 3 pieces) |
| -15 | 2" Cast Iron Extension Adapter |

Job Name: _____ Page No: _____
 Section No: _____ Contract: _____
 Schedule No: _____ Purchase Order No: _____