

Location: _____



F1570

**22" X 19 1/2" HEAVY DUTY
PARKING AREA CATCH BASIN**

Specification: MIFAB® Series F1570 - (A, B, C, D or E) powder epoxy coated heavy duty parking area catch basin with anchor flange, and extra heavy duty 22" x 19 1/2" (558 x 495) two section (specify material finish) grates with a free area of 155 square inches (100,000²). Grates to have maximum 11/16" (18) openings.

Function: Used in industrial factories, mechanical rooms, parking garages and other membrane finished areas. 22" x 19 1/2" tractor grate is used with all types of poured finished floors. The anchor flange provides maximum support for drain. Extra deep sump body is designed to handle large flows of water.

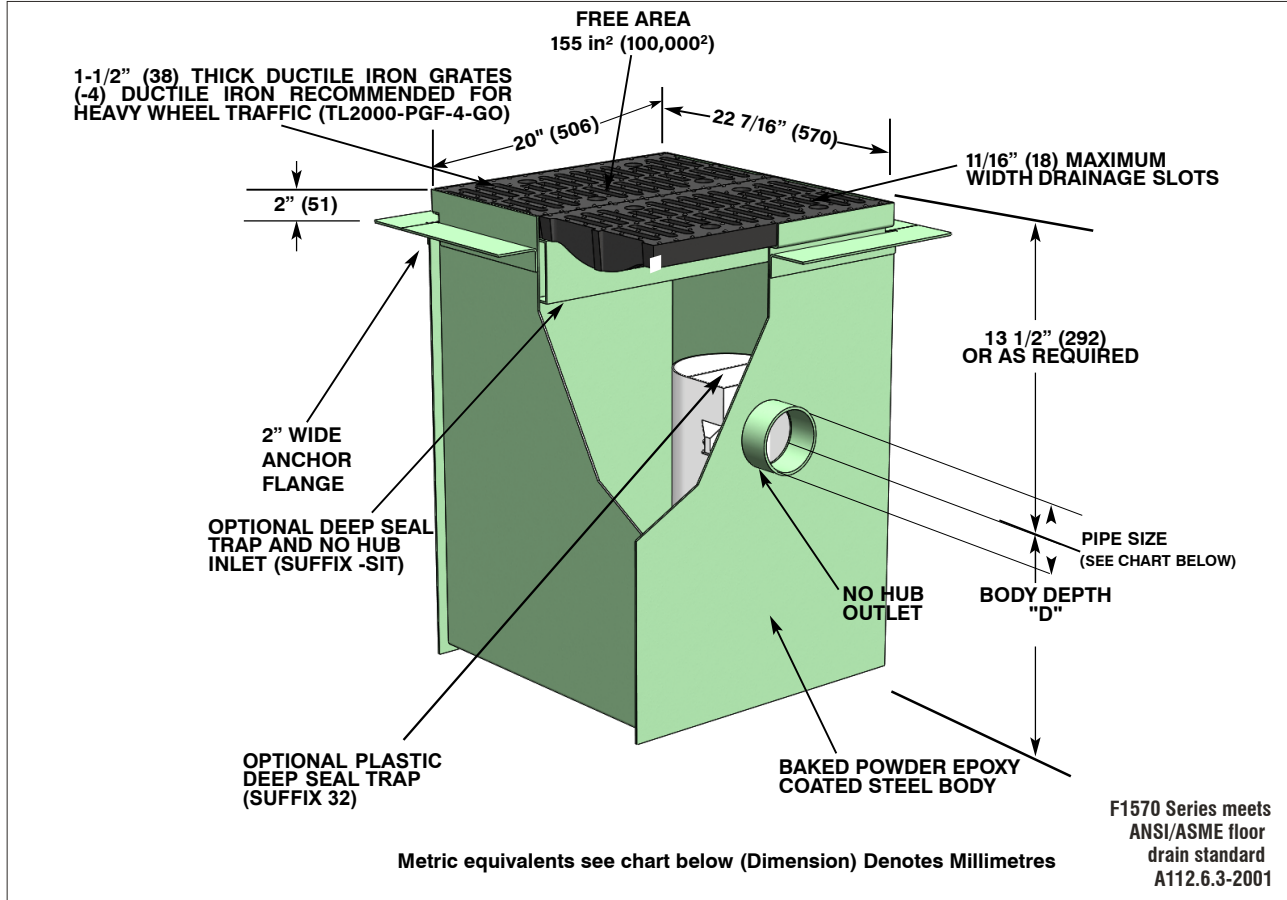

MODEL NO.	BODY DEPTH "D"	OVERALL DEPTH	NO HUB PIPE SIZE
F1570-A	18" (457)	31.50" (800)	2" (51)
F1570-B	24" (610)	37.50" (953)	3" (76)
F1570-C	30" (762)	43.50" (1105)	4" (102)
F1570-D	36" (914)	49.50" (1257)	6" (152)
F1570-E	SPECIAL	SPECIAL	

SUFFIX	OPTIONAL VARIATIONS
-3	Stainless steel strainer (vener)
-4	Ductile iron strainer
-6	Security screws (T-20 Torx & pin)
-12	Galvanized top assembly
-13	Galvanized body
-15	Extension
-28	Stainless steel body and grate (Type 304)
-32	Deep seal trap on outlet side

SUFFIX	OPTIONAL VARIATIONS
-95	Client logo
-BA	Minimum 51% material cost made in the USA
-C	Membrane clamp
-SI	No hub side inlet
-SIT	No hub side inlet trap
-PA	Pennsylvania Steel Act compliant product
(Specify)	Special outlet size

Job Name: _____ Page No: _____

Section No: _____ Contractor: _____

Schedule No: _____ Purchase Order No: _____