

Location: \_\_\_\_\_



**F1510**

**PARKING AREA DRAIN WITH 12" SQUARE HEAVY DUTY TRACTOR GRATE AND DEEP SUMP**

**Specification:** MIFAB® Series F1510 lacquered cast iron parking area drain with deep sump body, wide anchor flange, weepholes, and adjustable collar with square heavy duty epoxy ductile iron hinged tractor grate with four piece surface membrane clamp, sediment bucket and free area of 51 in<sup>2</sup> (32,903<sup>2</sup>).

**Function:** Used in mechanical rooms, parking garages and other membrane finished areas. 12" square, adjustable tractor grate is used with all types of poured finished floors. Hinged grate permits easy access to sediment bucket. Surface membrane clamp is ideal for areas that have a surface membrane.

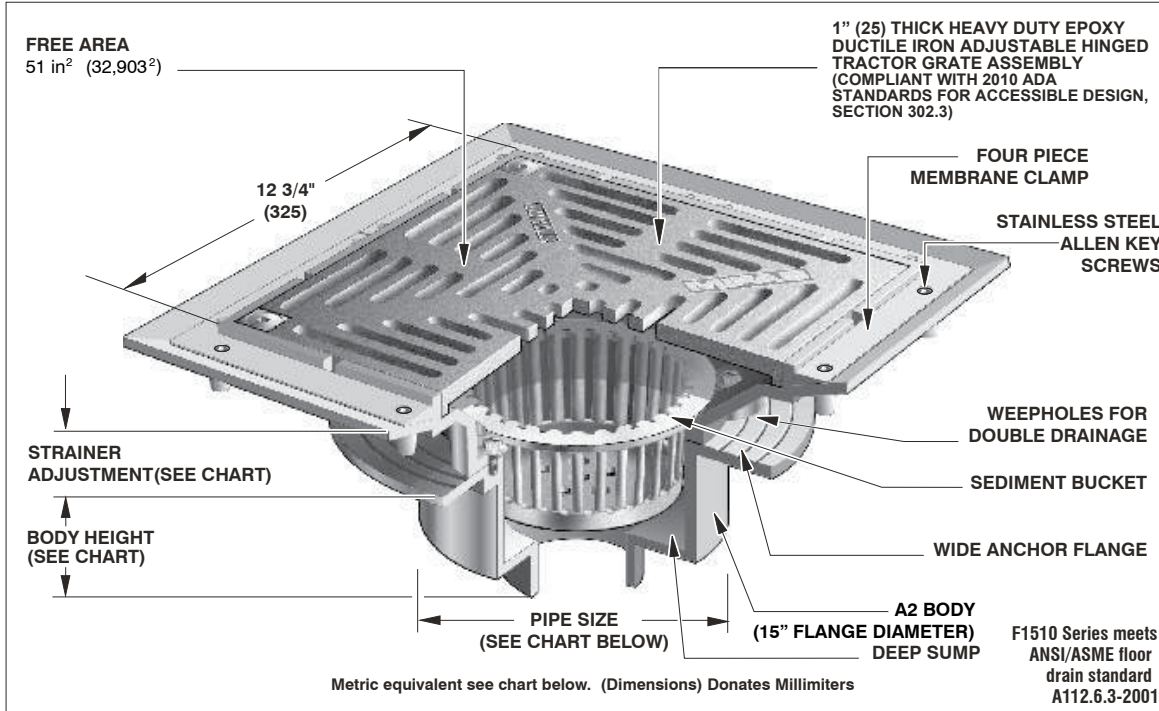

Metric equivalent see chart below. (Dimensions) Donates Millimeters

STRAINER DIAMETER	STRAINER ADJUSTMENT		FREE AREA	ANSI/ASME RATING		PIPE SIZE	BODY HEIGHT			
	MIN	MAX		LOAD RATING	D.I. (-4)		NO HUB (STANDARD)	PUSH ON (P)	THREADED (T)	INSIDE CAULK (X)
12" x 12" (305 x 305)	2 1/4" (57)	4 1/8" (105)	51 in <sup>2</sup> (32,903 <sup>2</sup> )	ANSI/ASME	2" (51)	6" (152)	6 1/8" (156)	5 7/16" (138)	6 1/4" (159)	7 1/8" (181)
				LOAD CLASS	3" (76)	6" (152)	6 1/8" (156)	5 7/16" (138)	6 1/4" (159)	7 3/8" (187)
				"SPECIAL DUTY"	4" (102)	6" (152)	6 1/8" (156)	5 7/16" (138)	6 1/4" (159)	7 3/8" (187)
				(OVER 10,000 LBS.)	5" (127)	6" (152)	—	5 7/16" (138)	6 1/4" (159)	—
					6" (152)	7 1/4" (184)	7" (178)	7" (178)	6 1/4" (159)	—

**SUFFIX      OPTIONAL VARIATIONS**

- 4      Ductile iron strainer
- 6      Security screws (T-20 Torx & pin)
- 7      1/2" trap seal primer connection
- 8      Backwater valve (2", 3", 4")
- 11     Acid resistant epoxy coated body
- 12     Galvanized top assembly
- 13     All galvanized
- 15     2" Extension (-TE)
- 28     Stainless steel body and grate (Type 304)
- 30     PVC socket connection body
- 31     ABS socket connection body Underdeck
- 40     clamp
- 41     Sump receiver

**SUFFIX      OPTIONAL VARIATIONS**

- 80     All aluminum (Medium duty load rated)
- 90     Threaded side outlet (2", 3", 4")
- 90NH   No hub side outlet (2", 3", 4")
- BA     Minimum 51% material cost made in the USA
- C      Membrane clamp
- HP     Heel proof grate (1/4" maximum grate opening size, -3 only)
- (Standard)   No hub outlet
- MG     MI-GARD Floor Drain Trap Sealer (2", 3" or 4")
- P      Push on outlet
- PA     Pennsylvania Steel Act compliant product
- T      Threaded outlet (2", 3", 4")
- X      Inside caulk outlet

CALIFORNIA PROPOSITION 65 WARNING. This product contains chemicals known to the State of California to cause cancer and birth defects or other reproductive harm.

Job Name: \_\_\_\_\_ Page No: \_\_\_\_\_  
 Section No: \_\_\_\_\_ Contractor: \_\_\_\_\_  
 Schedule No: \_\_\_\_\_ Purchase Order No: \_\_\_\_\_