

Location: _____



F1480

FLOOR DRAIN WITH 12" SQUARE HEAVY DUTY TRACTOR GRATE AND DEEP SUMP

Specification: MIFAB® Series F1480 epoxy coated large capacity floor drain with deep sump body, and standard 1" (25) thick, 12" (305) hinged square, (specify material finish) tractor grate with free area of 51 square inches (32,903²).

Function: Used in industrial factories, mechanical rooms, parking garages and other non-membrane finished areas. 12" square tractor grate is used with all types of poured finished floors. Hinged grate permits easy access to sediment bucket.

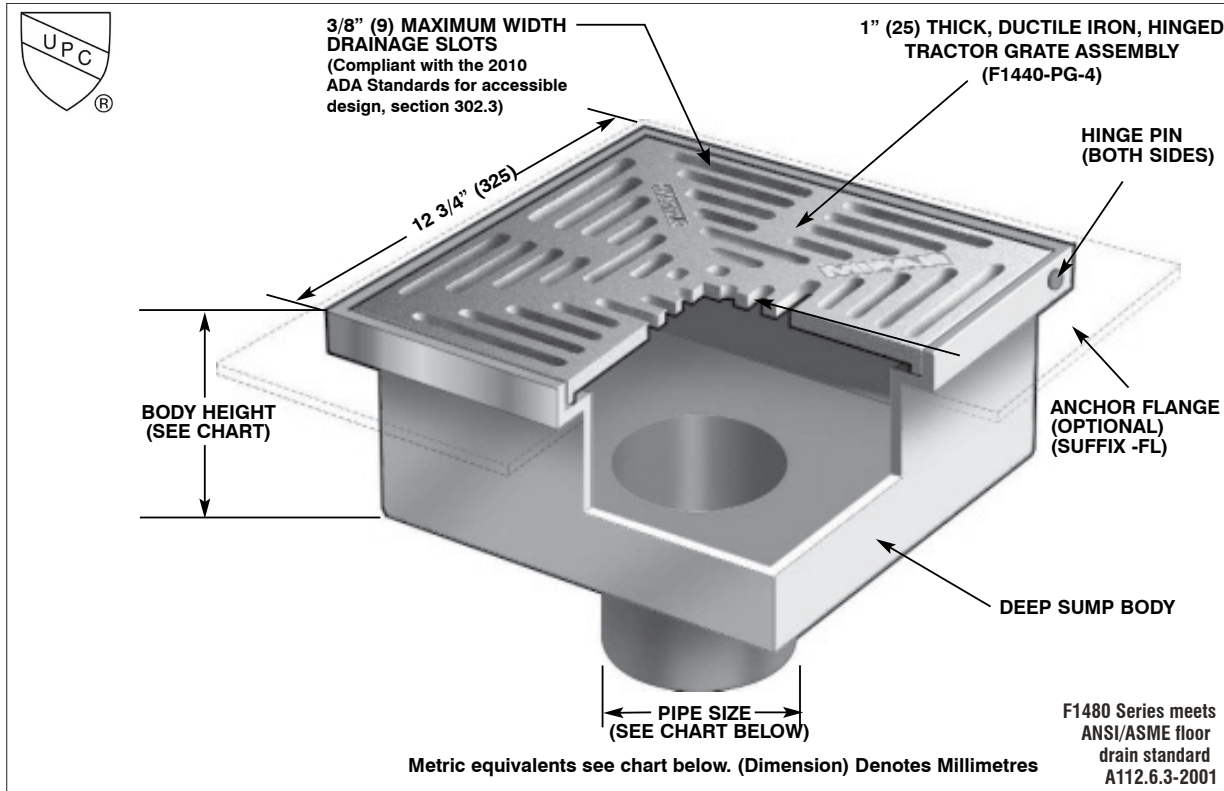

STRAINER DIAMETER	ANSI/ASME RATING		PIPE SIZE	BODY HEIGHT			
	FREE AREA	LOAD RATING		NO HUB (STANDARD)	PUSH ON (P)	THREADED (T)	INSIDE CAULK (X)
12" x 12" (305 x 305)	51 in ² (32,903 ²)	ANSI/ASME LOAD CLASS "SPECIAL DUTY" (OVER 10,000 LBS.)	2" (51)	11" (280)	11 3/4" (289)	10" (254)	11" (280)
			3" (76)	11" (280)	11 3/4" (289)	10" (254)	11" (280)
			4" (102)	11" (280)	11 3/4" (289)	10" (254)	11" (280)
			6" (152)	11" (280)	11 3/4" (289)	10" (254)	11" (280)

- SUFFIX OPTIONAL VARIATIONS**
- 1 Nickel bronze strainer (vener)
 - 3 Stainless steel strainer (vener)
 - 4 Ductile iron strainer
 - 5 Sediment bucket
 - 6 Security screws (T-20 Torx & pin)
 - 7 1/2" trap seal primer connection
 - 8 Backwater valve (2", 3", 4")
 - 11 Acid resistant epoxy coated body
 - 13 Galvanized body
 - 20 Secondary dome strainer
 - 21 Secondary flat stainless steel strainer (2", 3", 4")
 - 22 Less grate
 - 28 Stainless steel body and grate (Type 304)

- SUFFIX OPTIONAL VARIATIONS**
- 90 Threaded side outlet (2", 3", 4")
 - 90NH No hub side outlet (2", 3", 4")
 - BA Minimum 51% material cost made in the USA
 - C Membrane clamp
 - FL Anchor flange
 - HP Heel proof grate (1/4" maximum grate opening size, -3 only)
 - (Standard) No hub outlet
 - MG MI-GARD Floor Drain Trap Sealer (2", 3" or 4")
 - P Push on outlet
 - PA Pennsylvania Steel Act compliant product
 - T Threaded outlet (2", 3", 4")
 - X Inside caulk outlet

Job Name: _____ Page No: _____

Section No: _____ Contractor: _____

Schedule No: _____ Purchase Order No: _____