

Location: \_\_\_\_\_



**F1340-Y-Q**

**FLOOR DRAIN WITH 12" ROUND NON ADJUSTABLE TRACTOR GRATE**

**Specification:** MIFAB® Series F1340-Y-Q, lacquered cast iron shallow sump floor drain with anchor flange and non adjustable grate top assembly with standard 1" (25) thick, 12" round, (specify material finish) tractor grate.

**Function:** Used in heavy traffic areas such as parking garages, factories and loading docks. Shallow body is ideal for poured in place concrete decks where space is limited.

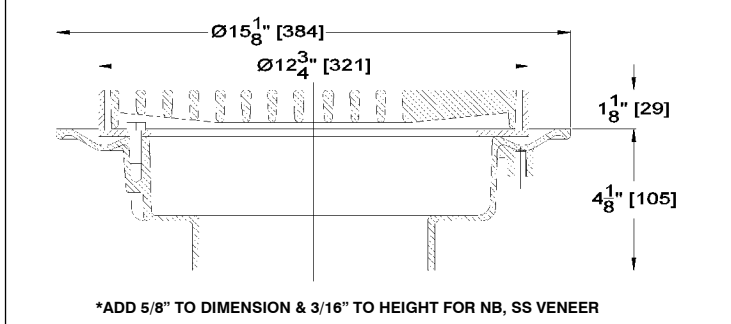
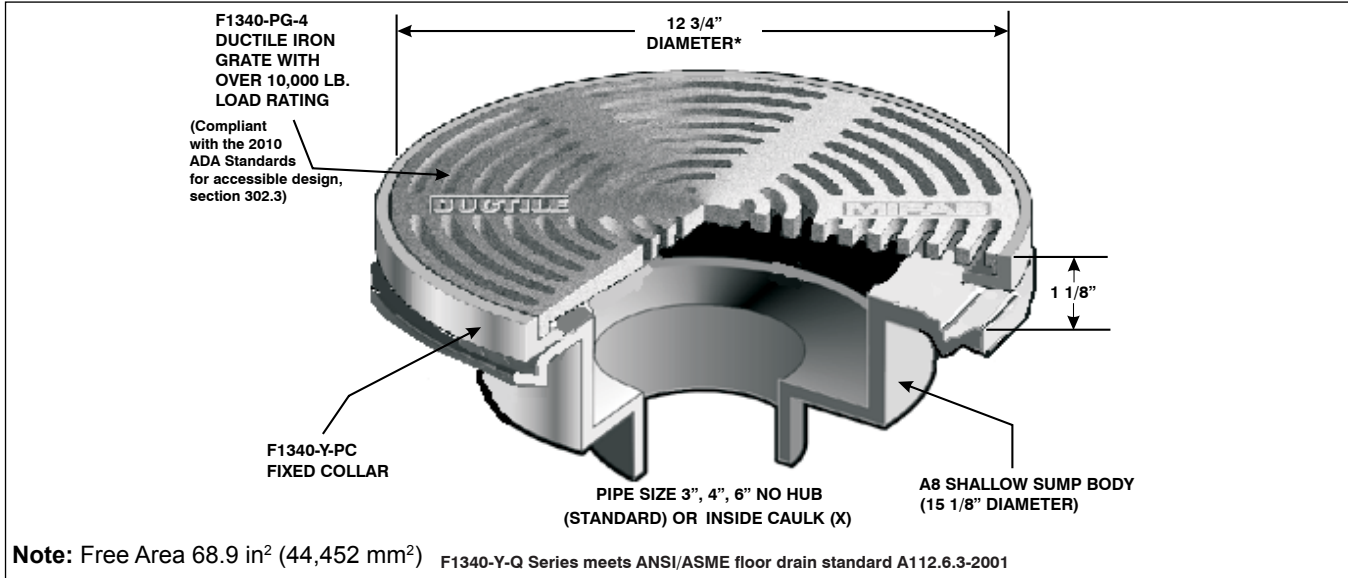

PIPE SIZE	BODY HEIGHT	
	NO HUB (STANDARD)	INSIDE CAULK (X)
3" (76)	4 1/8" (105)	4 1/2" (114)
4" (102)	4 1/8" (105)	4 1/2" (114)
6" (152)	4 1/8" (105)	4 1/2" (114)
8" (203)	4 1/8" (105)	4 1/2" (114)
10" (254)	4 1/8" (105)	4 1/2" (114)

SUFFIX	OPTIONAL VARIATIONS
<input type="checkbox"/> -1	Nickel bronze strainer (vener)
<input type="checkbox"/> -3	Stainless steel strainer (vener)
<input type="checkbox"/> -4	Ductile iron strainer
<input type="checkbox"/> -5	Sediment bucket
<input type="checkbox"/> -6	Security screws (T-20 Torx & pin)
<input type="checkbox"/> -7	1/2" trap seal primer connection
<input type="checkbox"/> -8	Backwater valve (2", 3", 4")
<input type="checkbox"/> -11	Acid resistant epoxy coated body
<input type="checkbox"/> -12	Galvanized top assembly
<input type="checkbox"/> -13	Galvanized body
<input type="checkbox"/> -14	Flat Strainer
<input type="checkbox"/> -15	Extension
<input type="checkbox"/> -16	Square Top
<input type="checkbox"/> -21	Secondary flat stainless steel strainer (2", 3", 4")
<input type="checkbox"/> -28	Stainless steel body (Type 304)
<input type="checkbox"/> -30	PVC socket connection body
<input type="checkbox"/> -31	ABS socket connection body
<input type="checkbox"/> -34	Closure plug

<input type="checkbox"/> -40	Underdeck clamp
<input type="checkbox"/> -41	Sump receiver
<input type="checkbox"/> -50	Lacquered cast iron funnel
<input type="checkbox"/> -90	Threaded side outlet (2", 3", 4")
<input type="checkbox"/> -90NH	No hub side outlet (2", 3", 4")
<input type="checkbox"/> -95	Client logo
<input type="checkbox"/> -BA	Minimum 51% material cost made in the USA
<input type="checkbox"/> -C2	High rough-in membrane clamp (min. 1 9/16" (40)
<input type="checkbox"/> -F4	4" Round funnel
<input type="checkbox"/> -F6	6" Round funnel
<input type="checkbox"/> -G	Oval 4" x 9" funnel
<input type="checkbox"/> -HP	Heel proof grate (1/4" maximum grate opening size, -3 only)
<input type="checkbox"/> -J	6" x 3" x 1" funnel
<input type="checkbox"/> (Standard)	No hub outlet
<input type="checkbox"/> -MG	MI-GARD Floor Drain Trap Sealer (2", 3" or 4")
<input type="checkbox"/> -PA	Pennsylvania Steel Act compliant product
<input type="checkbox"/> X	Inside caulk outlet
<input type="checkbox"/> -Z	Extended wide elastomeric flange

CALIFORNIA PROPOSITION 65 WARNING. This product contains chemicals known to the State of California to cause cancer and birth defects or other reproductive harm.

Job Name: \_\_\_\_\_ Page No: \_\_\_\_\_  
 Section No: \_\_\_\_\_ Contractor: \_\_\_\_\_  
 Schedule No: \_\_\_\_\_ Purchase Order No: \_\_\_\_\_