

Location: _____



F1170-C

FLOOR DRAIN WITH MULTI INLETS, ROUND STRAINER AND INTEGRAL TRAP

Specification: MIFAB® Series F1170-C lacquered cast iron body and anchor flange, weepholes, 3" or 4" no hub side outlet, integral deep seal trap with cleanout plug and adjustable (specify material finish) strainer with T-20 torx and pin security screws. (Specify -44, 2" (51) no hub inlets as shown and required. Maximum three @ 90 degrees. Specify location -A, B, or C.)

Function: Used in toilets, kitchens and other membrane finished areas where additional inlets are required to receive drainage. Integral deep seal trap prevents sewer gas from entering area.

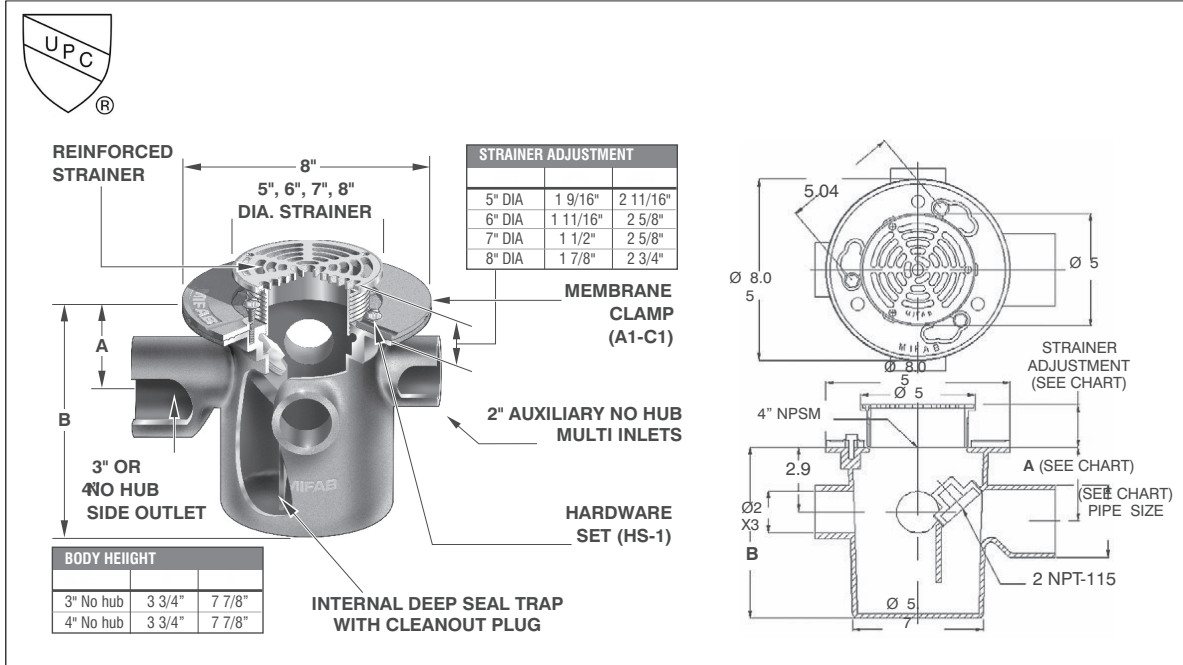

(*) Denotes strainer size (5, 6, 7 or 8)
 (**) Denotes strainer finish (-1 or -3)

MODEL NUMBER	OUTLET SIZE	WT. LBS.	STRAINER ADJUSTMENT
F1173, 4-C-5	3" 4"	21.00	5" DIA
F1173, 4-C-6	3" 4"	21.50	6" DIA
F1173, 4-C-7	3" 4"	22.00	7" DIA
F1173, 4-C-8	3" 4"	23.00	8" DIA

SUFFIX OPTIONAL VARIATIONS

- 1 Nickel bronze strainer and cover
- 3 Stainless steel strainer
- 4 Ductile iron grate (5" x 8" only) (standard)
- 5 Sediment bucket
- 6 Security screws (T-20 Torx & pin)
- 7 1/2" trap seal primer connection
- 8 Backwater valve (2", 3", 4")
- 11 Acid resistant epoxy coated body
- 13 Galvanized body
- 15 Extension
- 34 Closure plug
- 44 2" (51) no hub inlet (specify A, B, C locations)
- 50 Lacquered cast iron funnel

SUFFIX OPTIONAL VARIATIONS

- 95 Client logo
- BA Minimum 51% material cost made in the USA
- C2 High rough-in membrane clamp (min. 1 9/16" 40)
- F4 4" Round funnel
- F6 6" Round funnel
- G Oval 4" x 9" funnel
- HP Heel proof grate (1/4" maximum grate opening size, -3 only)
- J 6" x 3" x 1" funnel
- MG MI-GARD Floor Drain Trap Seal (2", 3" or 4")
- PA Pennsylvania Steel Act compliant product
- Z Extended wide elastomeric flange

Job Name: _____ Page No: _____

Section No: _____ Contractor: _____

Schedule No: _____ Purchase Order No: _____