

Location: _____



F100

ROUND ADJUSTABLE FLOOR DRAIN WITH FLANGE

Specification: MIFAB Series F100 lacquered cast iron floor drain with anchor flange, and standard satin finished nickel bronze or ductile iron strainer with vandal resistant stainless steel allen key screws. Trap Seal Primer tapping included with all bodies.

Function: Used in showers, kitchens, restrooms, and other non-membrane finished areas.

F104-30-5-1

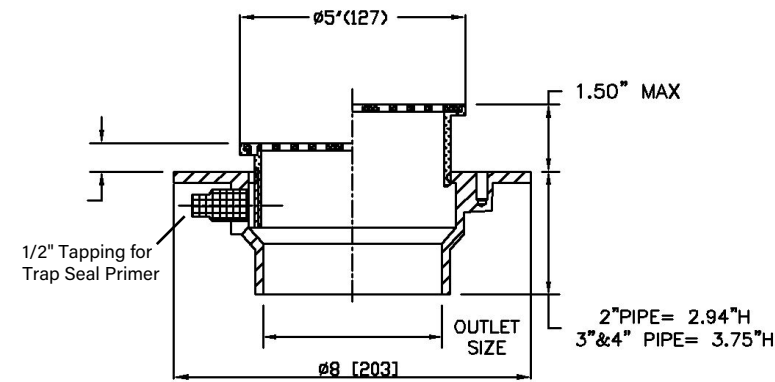
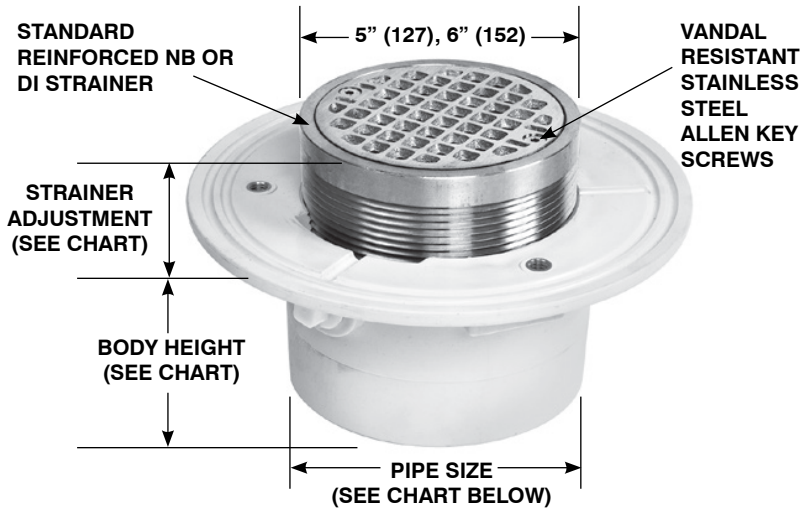

F104-5-1

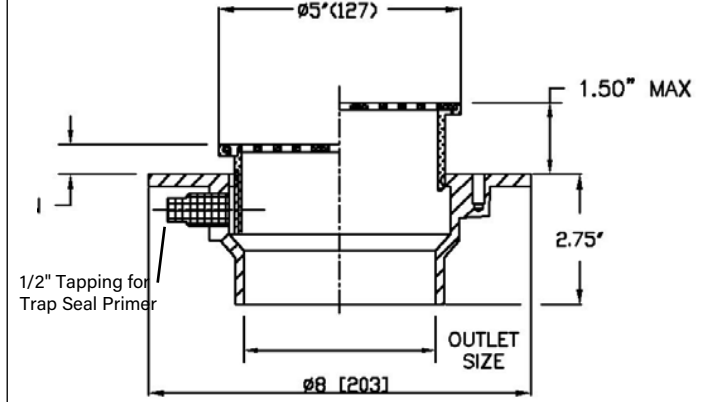
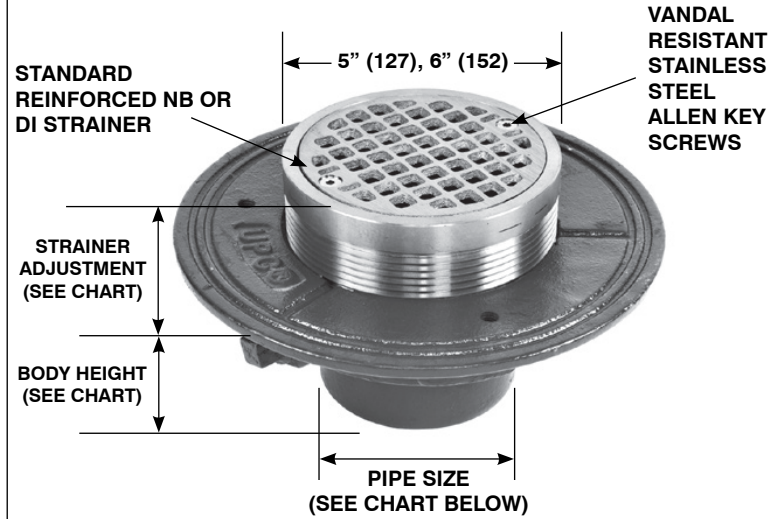

SUFFIX OPTIONAL VARIATIONS

-6 Vandal proof

STRAINER DIAMETER	STRAINER ADJUSTMENT		ANSI/ASME RATING		PIPE SIZE	NO HUB (STANDARD)	PUSH ON (P)	PVC/ABS (-30)/(-31)	
			FREE AREA	LOAD RATING					
	MIN	MAX		N.B. (-1)					D.I. (-4)
5" (127)	1/2" (13)	1 1/2" (38)	8 in ² (5200 ²)	Up to 2,000 Lbs.	Over 10,000 Lbs.	2" (51)	3" (76)	3 3/8" (86)	2 15/16" (75)
6" (152)	11/16" (17)	1 1/2" (38)	9 in ² (5800 ²)	Up to 2,000 Lbs.	--	3" (76)	3" (76)	3 3/8" (86)	3 3/4" (95)
						4" (102)	3" (76)	3 3/8" (86)	3 3/4" (95)

Job Name: _____
 Section No: _____
 Schedule No: _____

Page No: _____
 Contract: _____
 Purchase Order No: _____