

Location: _____



DSAW

WIDEBODY, DUCT SUPPORT SERIES

Specification:

Telescopic Crossbeam

Outer Piece Dimensions - 1 7/8" x 1 7/8"

Inner Piece Dimensions - 1 5/8" x 1 5/8"

Material - 12 gauge, galvanized steel

Vari-Angle Bracket

Dimensions - 5 7/8" x 1 7/8"

Material - 1/4" Hot-rolled, zinc plated carbon steel

Base (DSA10)

Dimensions - 2 1/4" Height x 12" Width x 12" Length

Maximum Load - 1,000 lbs.

Material (both models) - 100% recycled rubber, UV resistant



**Environmentally Friendly
made from
100% recycled tires**



Consult with roofing consultant for allowable loads.

Function: The DSAW Series is designed specifically for ductwork. The telescopic crossbeam allows for easy size adjustments. The bases feature vari-angle supports to adapt to any roof pitch and are made of 100% recycled rubber. Wide bases are used with the DSAW Series.

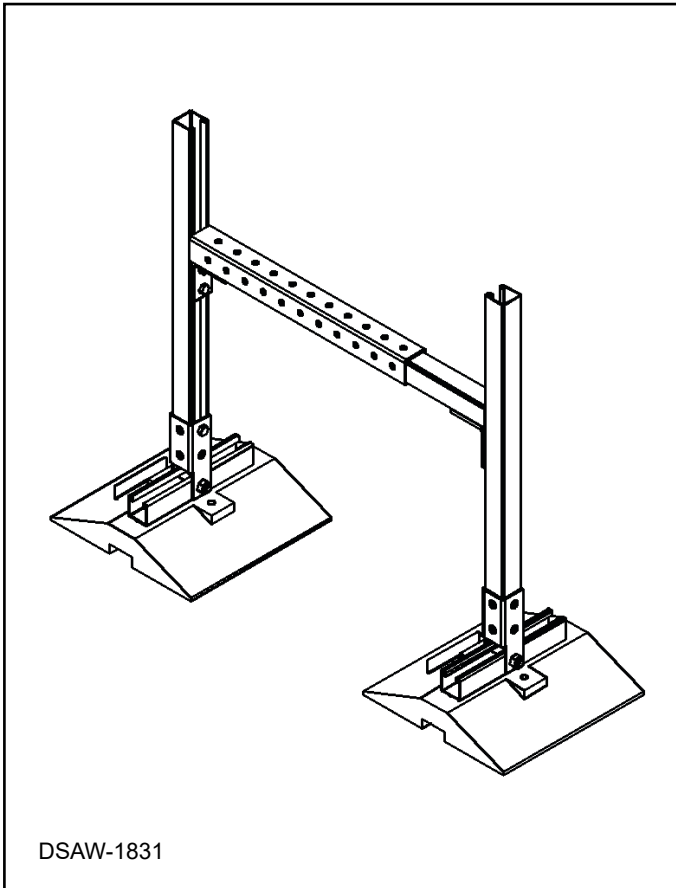

MODEL NO.	WIDTH (W) MIN	WIDTH (W) MAX	BASE LENGTH (L)	WEIGHT
DSAW-1831	18" (457)	31" (787)	12" (305)	29.90 lbs.
DSAW-3157	31" (787)	57" (1448)	12" (305)	35.10 lbs.
DSAW-57102	57" (1448)	102" (2591)	12" (305)	40.10 lbs.

Uprights are not included. Strut can be cut to suit job site. Channel also available in corrosion resistant stainless steel or aluminum.

CALIFORNIA PROPOSITION 65 WARNING. This product contains chemicals known to the State of California to cause cancer and birth defects or other reproductive harm.

Job Name: _____ Page No: _____
 Section No: _____ Contractor: _____
 Schedule No: _____ Purchase Order No: _____