

Location: _____



CRE

**EXTENDED
ROLLER SERIES, REGULAR BASE**

Specification:

DIMENSIONS:

Base - Width of 6" x Length of 9.6"

Roller Width - 3", 4", or 6" rollers are available (See Chart)

Total Height to Roller Centre - ranges from 8" to 12" (See Chart)

MATERIAL:

Base - 100% recycled rubber, UV resistant

Roller - TPO (56EA)

Extending Rods and Horizontal Rod - 1/2" electro zinc plated all threaded rod risers

Maximum Load - 400 lbs.



**Environmentally Friendly
made from
100% recycled tires**

Function: The CRE Series is designed for superior support of gas and refrigeration pipes at a higher elevation from the roof surface. The roller allows for longitudinal movements of the pipe. This support is suitable for most types of roofing material or other flat surfaces.



Consult with roofing consultant for allowable loads.

U.S. Patent No. 7,866,093

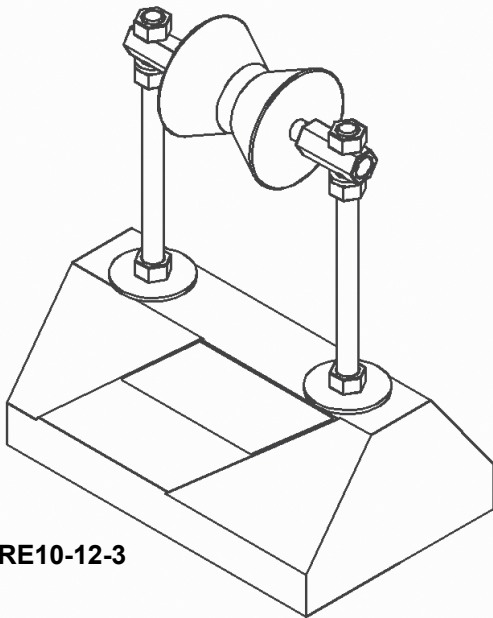

CRE10-12-3



Note: CRE10-12-3 illustrated

MODEL NO.	PIPE SIZE (OD)	OVERALL HEIGHT (H) TO ROLLER CENTRE (ADJUSTABLE)	WIDTH (W)	LENGTH (L)	WEIGHT
CRE10-12-3	Up to 3" Pipe	12" (305)	6" (152)	9.6" (244)	7.10 lbs.
CRE10-12-4	Up to 4" Pipe	12" (305)	6" (152)	9.6" (244)	7.50 lbs.

CALIFORNIA PROPOSITION 65 WARNING. This product contains chemicals known to the State of California to cause cancer and birth defects or other reproductive harm.

Job Name: _____

Page No: _____

Section No: _____

Contractor: _____

Schedule No: _____

Purchase Order No: _____

MIFAB reserves the right to make changes in material and design without formal notice and obligation.

USA: 1-800-465-2736 www.mifab.com CAN: 1-800-387-3880