

Location: _____



BV1290

DRAIN TILE SUMP

Specification: MIFAB® BV1290 Series fabricated 10 gauge powder epoxy, acid resistant coated steel drain tile sump with 8" diameter ductile iron grate and multiple outlets.

Function: The BV1290 terminal valve is to provide a sump with multiple connections that the foundation drain lines can connect to.

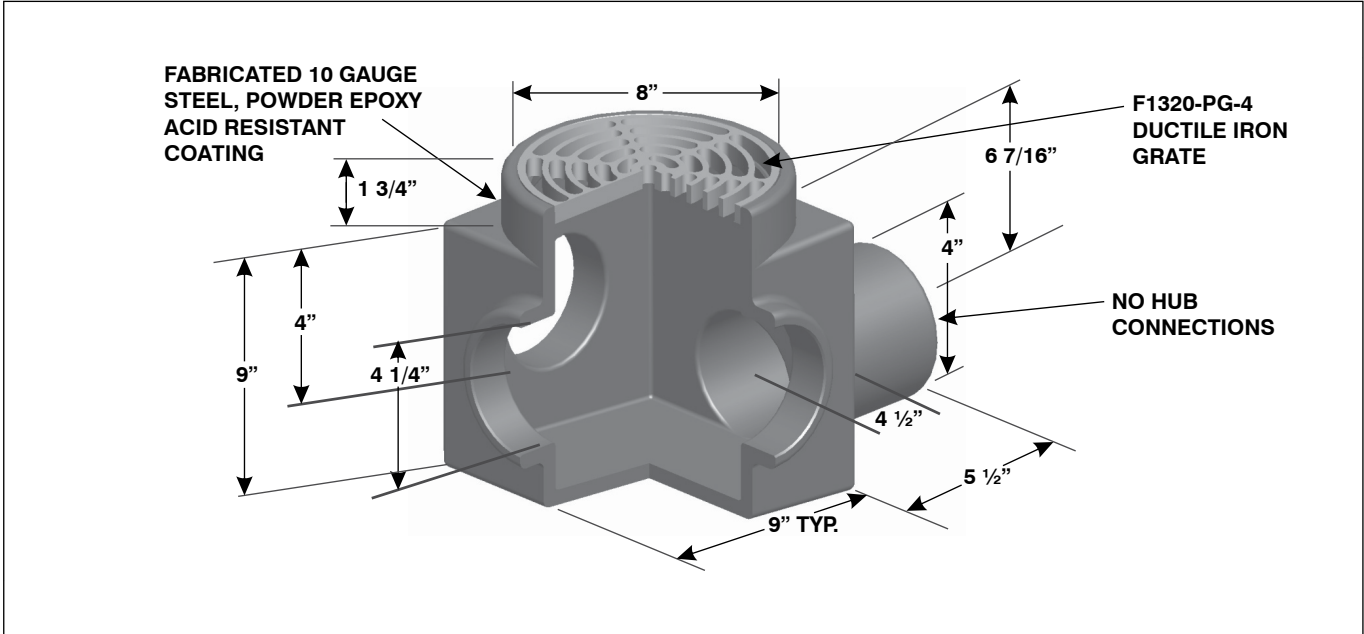

Note: The function of the BV1290 is to provide a sump with multiple inlets that the foundation drain lines connect to.

MODEL NUMBER	WEIGHT (Lbs.)	FREE AREA SQUARE DRAIN	OUTLET SIZE
BV1294	50	14.25"	4"

SUFFIX	OPTIONAL VARIATIONS
-1	Nickel Bronze grate and frame (vener)
-3	Stainless Steel grate and frame (vener)
-13	All Galvanized
-25	Solid cover
-BA	Minimum 51% material cost made in the USA
-PA	Pennsylvania Steel Act compliant product

CALIFORNIA PROPOSITION 65 WARNING. This product contains chemicals known to the State of California to cause cancer and birth defects or other reproductive harm.

Job Name: _____ Page No: _____
 Section No: _____ Contractor: _____
 Schedule No: _____ Purchase Order No: _____