

**MIFAB®****BV1000-CS****EPOXY COATED ACCESS HOUSING AND COVER FOR DEEP ROUGH IN**

Specification: MIFAB® Series BV1000-CS powder epoxy coated 10 gauge fabricated steel access cover and housing with gasketed, non skid, reinforced steel cover for deep rough in.

Function: Typically used with MIFAB's BV1000 Series of backwater valves to provide protection of the valve and access from the top.

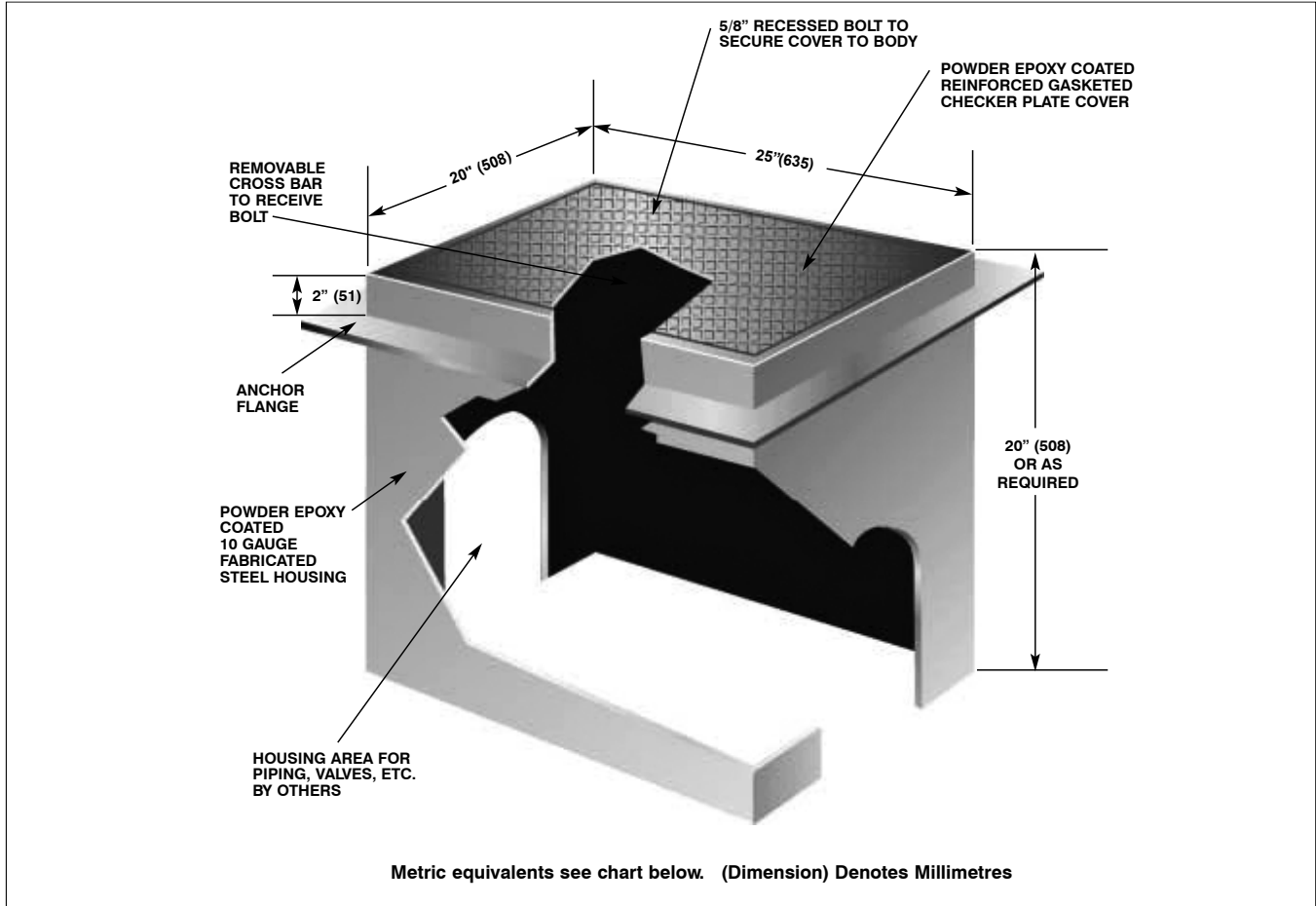

Model #	Size	Weight
BV1000-CS	(2" - 10" only) Specify Depth (up to 30")	150.00
	Add per inch over 30"	+22lbs/in
BV1012-CS	(for 12" model) Specify Depth (up to 30")	175.00
		+26lbs/in

SUFFIX	OPTIONAL VARIATIONS
-13	All galvanized
-BA	Minimum 51% material cost made in the USA
-PA	Pennsylvania Steel Act compliant product

CALIFORNIA PROPOSITION 65 WARNING. This product contains chemicals known to the State of California to cause cancer and birth defects or other reproductive harm.

Job Name: _____ Page No: _____
 Section No: _____ Contractor: _____
 Schedule No: _____ Purchase Order No: _____