

Location: _____



A8 BODY

A8 BODY

Specification: MIFAB's A8 body series manufactured with 15" diameter top flange designed with recessed grooves cast into the top for secure water-proofing sealing and four 3/8" tappings on the top flange and underneath the top flange to receive hardware to connect with MIFAB's various membrane clamps and/or underdeck clamps. Available in cast iron in various outlet connections sizes (see chart below).

Function: Universal body that is used with all MIFAB F1340-Y-Q and F1440-Y-Q Series of floor and area drains.

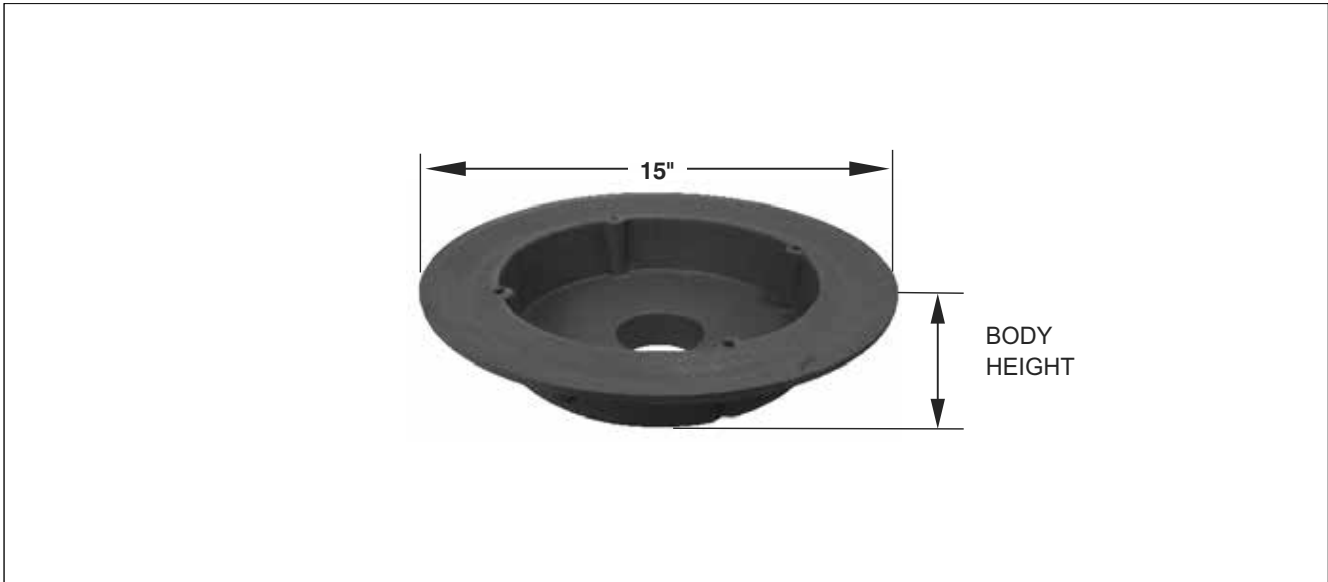

PIPE SIZE	NO HUB (STANDARD)	INSIDE CAULK (X)
2", 3", 4", 5" 6"	4 1/8"	5.05"

CALIFORNIA PROPOSITION 65 WARNING. This product contains chemicals known to the State of California to cause cancer and birth defects or other reproductive harm.

Job Name: _____

Page No: _____

Section No: _____

Contractor: _____

Schedule No: _____

Purchase Order No: _____

MIFAB reserves the right to make changes in material and design without formal notice and obligation.

USA: 1-800-465-2736 www.mifab.com CAN: 1-800-387-3880

2022-06-20