

Location: _____



A2-XY

A2-XY EXTENSION

Specification: MIFAB®'s A2-XY lacquered cast iron extension with vertical weepholes with adjustment range of 3 7/8" to 5 3/8".

Function: Used with A2 and A3 bodies to receive the F1340-TA, F1360-TA, F1440-TA and F1460-TA top assemblies with an adjustment range of 3 7/8" to 5 3/8". The top assembly can be adjusted side to side to align with the floor tiles without changing vertical height.

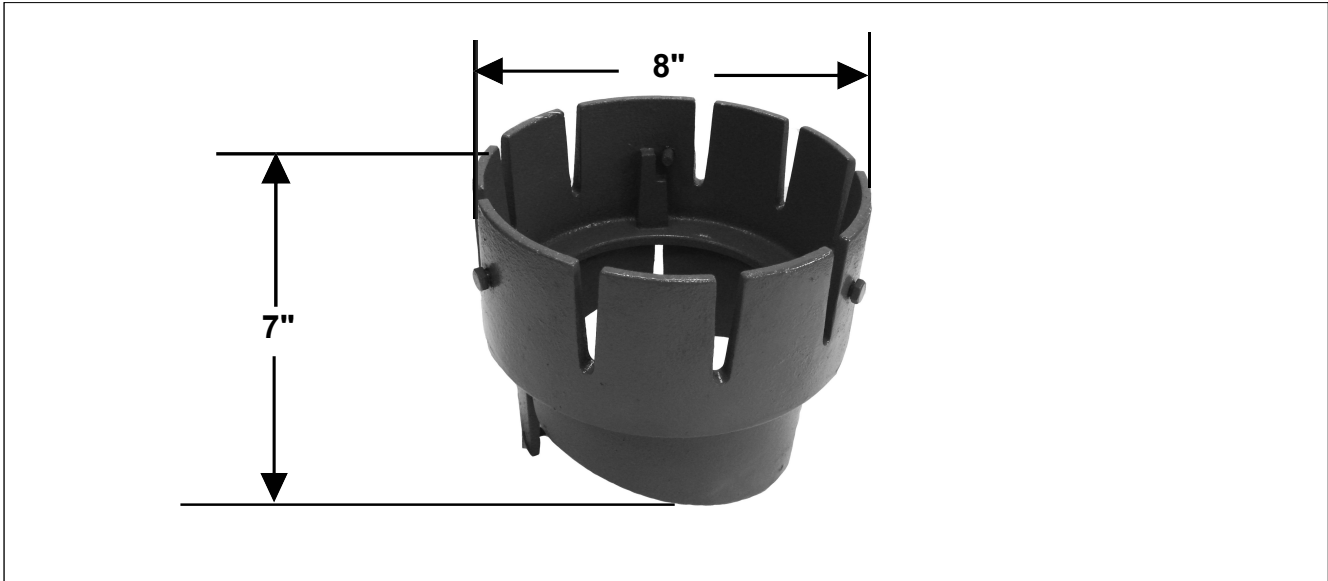

PART NO.	WEIGHT (LBS.)
A2-XY	15.00

SUFFIX	OPTIONAL VARIATIONS
-11	Acid resistant powder epoxy coating
-13	Galvanized coating
-83	Galvanized coating

CALIFORNIA PROPOSITION 65 WARNING. This product contains chemicals known to the State of California to cause cancer and birth defects or other reproductive harm.

Job Name: _____

Page No: _____

Section No: _____

Contractor: _____

Schedule No: _____

Purchase Order No: _____

MIFAB reserves the right to make changes in material and design without formal notice and obligation.

USA: 1-800-465-2736 www.mifab.com CAN: 1-800-387-3880

2021-06-04