

Location: _____



A2-BP

BEARING PAN / SUMP RECEIVER FOR LARGE SUMP ROOF DRAINS

Specification: A2-BP, 24" x 24" 18 gauge, lacquered steel bearing pan / sump receiver with rounded corners and anchor slots in each corner. Included with the A2-BP is a quantity of three 16" threaded rods and hardware for optional roof drain extension.

Function: Center recess of the A2-BP is designed to receive the top flange of the A2 body. The A2 body flange is placed into this recess to ensure easy flow of water from the roof deck into the sump of the roof drain. Anchor slots in each corner permit bolting to the roof deck. The three 16" long threaded rods and hardware provided permits the A2 body to be elevated off of the roof deck to meet the insulation thickness above the deck. Hardware is also provided to bolt the A2 body to the A2-BP so that the typical underdeck clamp is not required.

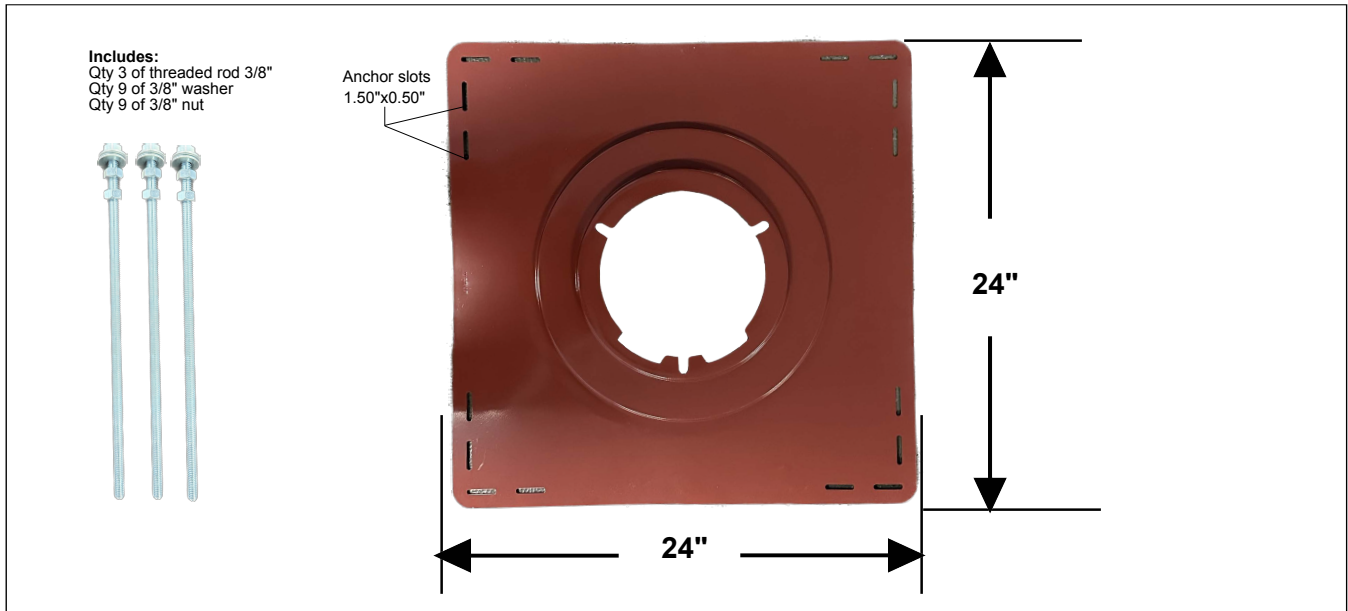

PART NO.	DESCRIPTION	WEIGHT
A2-BP	Sump receiver (R1200)	6.50

CALIFORNIA PROPOSITION 65 WARNING. This product contains chemicals known to the State of California to cause cancer and birth defects or other reproductive harm.

Job Name: _____

Page No: _____

Section No: _____

Contractor: _____

Schedule No: _____

Purchase Order No: _____

MIFAB reserves the right to make changes in material and design without formal notice and obligation.

USA: 1-800-465-2736 www.mifab.com CAN: 1-800-387-3880

2024-01-23