

Location: _____



T1320-FL

6" WIDE, NEUTRAL SLOPED, CAST IRON BODY AND GRATE SYSTEM

Specification: MIFAB® Series T1320-FL, 6" wide, 6 3/4" deep, 20" long, non sloped modular trench drain with lacquered cast iron body sections. Each body has a 2" wide anchor flange cast into each side recessed 2.20" down from the top. Bodies have a radiused bottom and flanged ends to connect to each other with a neoprene rubber gasket in between. End outlets are available in 2", 3" or 4" no hub outlet connections (specify outlet connection size) and bottom outlets are available in 2", 3", or 4" no hub outlet connections (specify outlet connection size). 20" long, Class E, H-20 ductile iron grate is provided as standard (Suffix -4) along with grate lockdown hardware for each grate to secure to the body. Class A, B, C and D grates are also available. End caps and catch basins are also available.

Function: Used in vehicle washdown areas, loading and parking areas, at the bottom of parking garages, warehouses and other locations that have heavy vehicle traffic. An infinite number of body sections can be assembled together to serve any requirement.

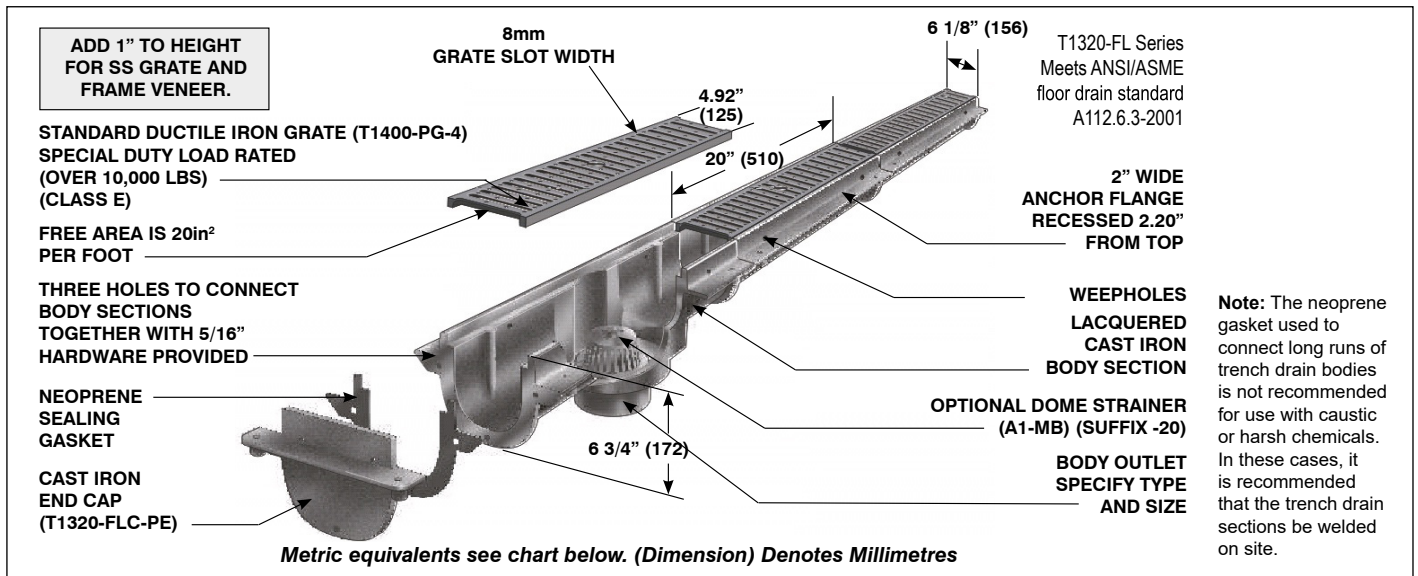

Note: Specify total length of trench drain required in 20" long sections. Section "A" is standard with a bottom outlet (specify bottom outlet connection type and number and location of outlets required). Section "B" does not have a bottom outlet. Any number of Sections "A" and "B" can be bolted together to produce any length required.

MODEL NUMBER	SIZE	MATERIAL	FRAME MATERIAL
T1322,3,4-FL-4	6 1/8" x 20" section	Cast Iron body, DI grate	Cast Iron
T1322,3,4-FL-4-3	6 1/8" x 20" section	Cast iron body, DI grate W/SS veneer	SS Veneer

Suffix	Description
-5	Sediment bucket (per outlet section)
-6	Vandal proof grate (per grate) (H-1072B) (lockdown grate to body)
-8	Backwater valve (per piece)(BV1254)
-11	All acid resistant epoxy coated (per 12" section)
-12	Galvanized grate
-13	All galvanized (per 12" section)
-20	Dome bottom outlet strainer (per piece)
-C	Membrane clamp (per foot)
P	Push on bottom outlet (2", 3" or 4")
S	End outlet (No Hub only, 4")
T	Threaded bottom outlet (2", 3" or 4")
X	Inside caulk bottom outlet (2" or 3")

CALIFORNIA PROPOSITION 65 WARNING. This product contains chemicals known to the State of California to cause cancer and birth defects or other reproductive harm.

Job Name: _____ Page No: _____
 Section No: _____ Contractor: _____
 Schedule No: _____ Purchase Order No: _____