

Location: \_\_\_\_\_



**MH-200**

**SIPHONIC ROOF DRAIN FOR BALCONIES / TERRACES**

**Specification:** MIFAB® / Hydromax Series MH-200 fabricated Type 304 stainless steel siphonic roof drain with 2" no hub outlet connection, anchor flange, waterproofing membrane clamp ring and air baffle / inducer with Type 304 stainless steel allen key hardware. The anchor flange, waterproofing membrane clamp ring and air baffle / inducer are all made from Type 304 stainless steel.

**Function:** Used for installation in terraces and / or balconies as part of a siphonic roof drainage system where foot traffic exists.

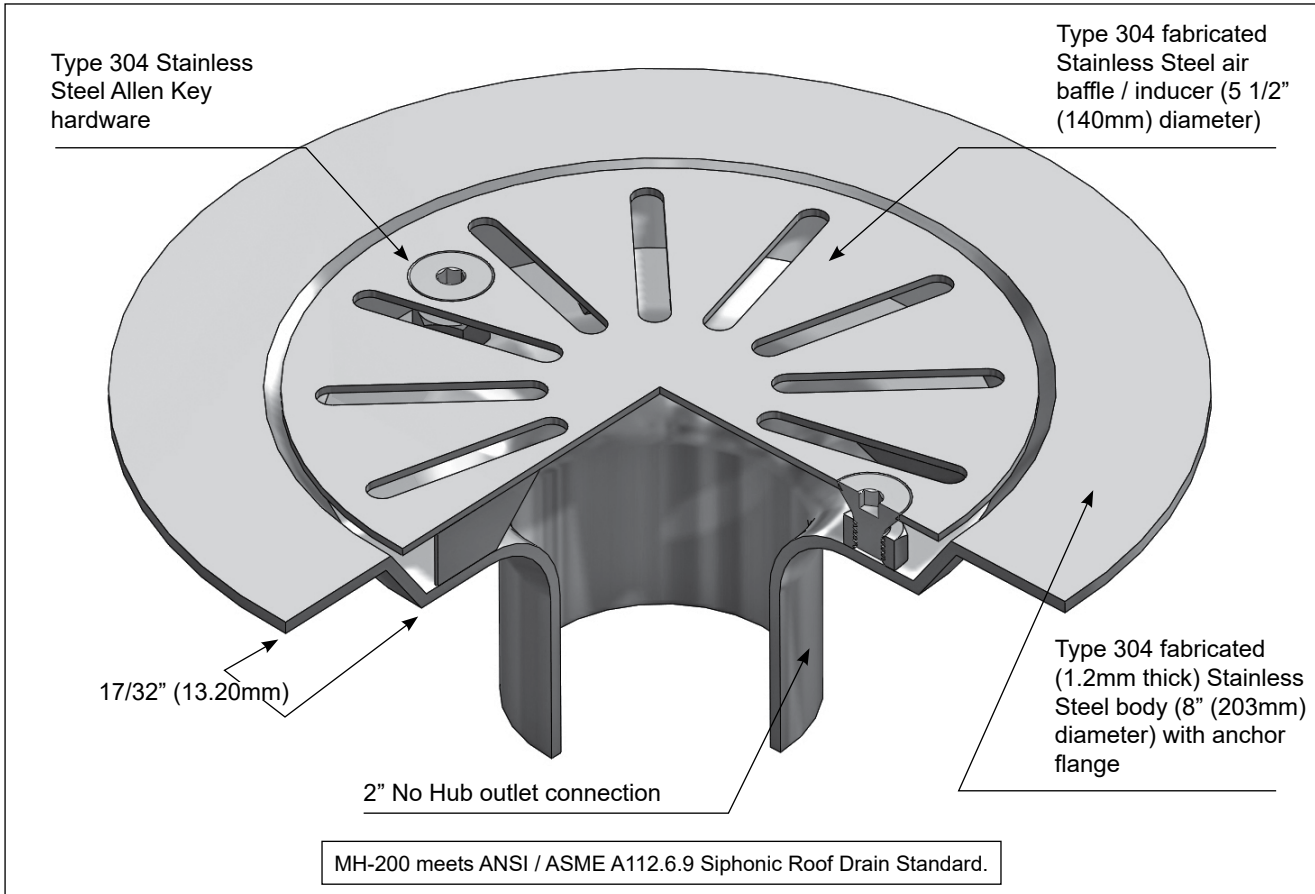

MODEL NUMBER	PIPE SIZE	BODY HEIGHT NO HUB (STANDARD)	PERFORMANCE INFORMATION		
			Resistance Value (K)	Minimum Flow Rate (GPM)	Maximum Flow Rate (GPM)
MH-200	2" (52)	2 11/16" (68)	0.20	23.00	190.50

SUFFIX	OPTIONAL VARIATIONS
-BA	Buy American Act Compliant product
-PA	Pennsylvania Steel Act compliant product

CALIFORNIA PROPOSITION 65 WARNING. This product contains chemicals known to the State of California to cause cancer and birth defects or other reproductive harm.

Job Name: \_\_\_\_\_ Page No: \_\_\_\_\_  
 Section No: \_\_\_\_\_ Contractor: \_\_\_\_\_  
 Schedule No: \_\_\_\_\_ Purchase Order No: \_\_\_\_\_

MIFAB® reserves the right to make changes in material and design without formal notice or obligation. USA: 1-800-465-2736 www.mifab.com CAN: 1-800-387-3880