

Location: \_\_\_\_\_



**MIFAB® T1500-PG-ADA**

**6" WIDE, DUCTILE IRON, HEAVY DUTY (LOAD CLASS C), HEEL SAFE, ADA COMPLIANT GRATE**

**Specification:** MIFAB T1500-PG-ADA, heavy duty, (Load Class C), heel safe, ADA compliant, ductile iron grate is 4.80" wide x 19.68" long, weighing 4.83 lbs. per linear foot. The grate has .23" wide x .90" long slots and has a free open area of 26.35 square inches and is H-20 and FAA load rated. The grate is secured to the body with a four point self-locking (snap in) system. Manufactured from ductile iron material conforming to ASTM A 536-84, Grade 65-45-12.

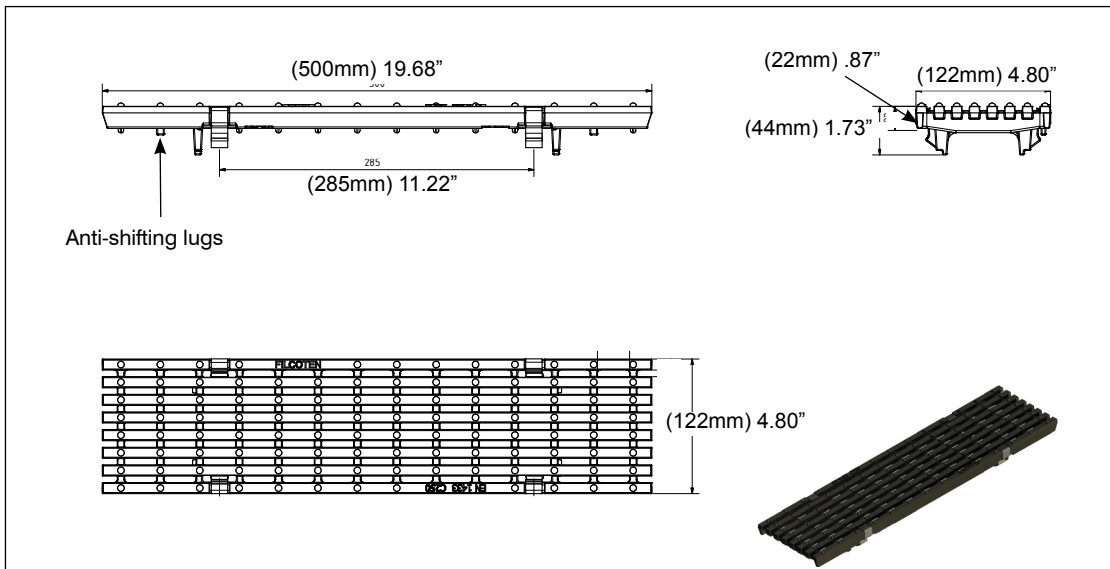
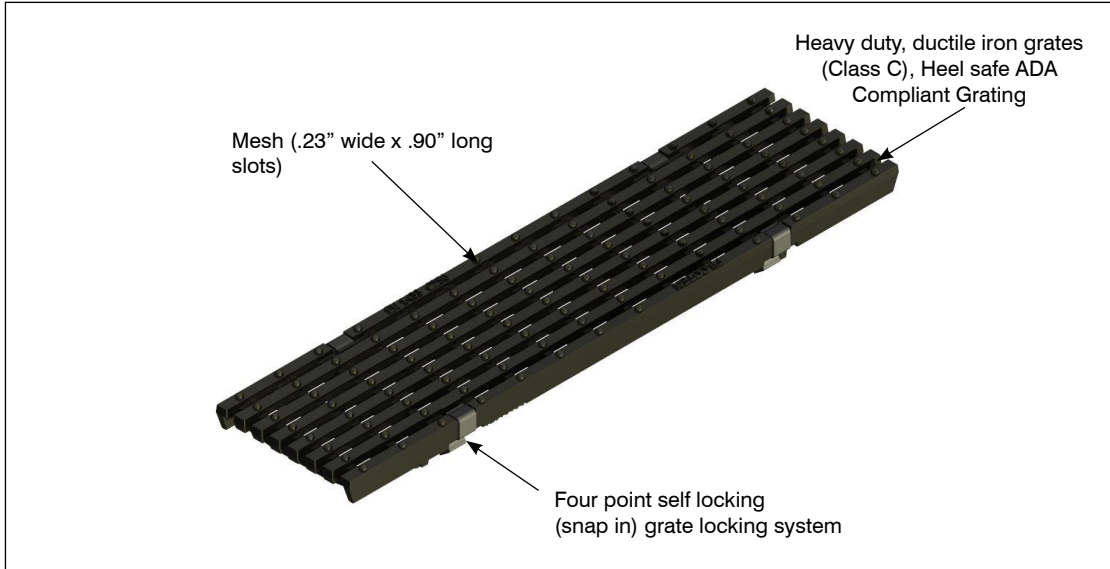

Load Class C- Heavy Duty, DIN 19580, 56,000 lbs. 1,162 psi. For commercial pneumatic tire traffic patterns and tractor trailers.

Job Name: _____	Page No: _____
Section No: _____	Contract: _____
Schedule No: _____	Purchase Order No: _____

MIFAB reserves the right to make changes in material and design without formal notice or obligation.

USA: 1-800-465-2736 [www.mifab.com](http://www.mifab.com) CAN: 1-800-387-3880