

Location: \_\_\_\_\_



**C1100-T**

**FLOOR CLEANOUT FOR TILE AREAS WITH ROUND ADJUSTABLE COVER AND PLUG**

**Specification:** MIFAB® C1100-T Series adjustable floor cleanout with lacquered cast iron body and anchor flange, secondary "O" ring Test Seal, 4" diameter cleanout opening and round scoriated combined cover and plug top assembly (specify material type) with 1/8" recess for tile and stainless steel vandal proof allen key screws and primary gasket seal. (For membrane floors, add Suffix -C for the membrane clamp.)

**Function:** Used in finished floors to provide emergency access to the plumbing lines for removal of blockages. Replacement of the surface level cover/plug with the neoprene gasket glued to the underside provides visual evidence that the cleanout has been properly resealed to prevent harmful sewer gases from entering the building.

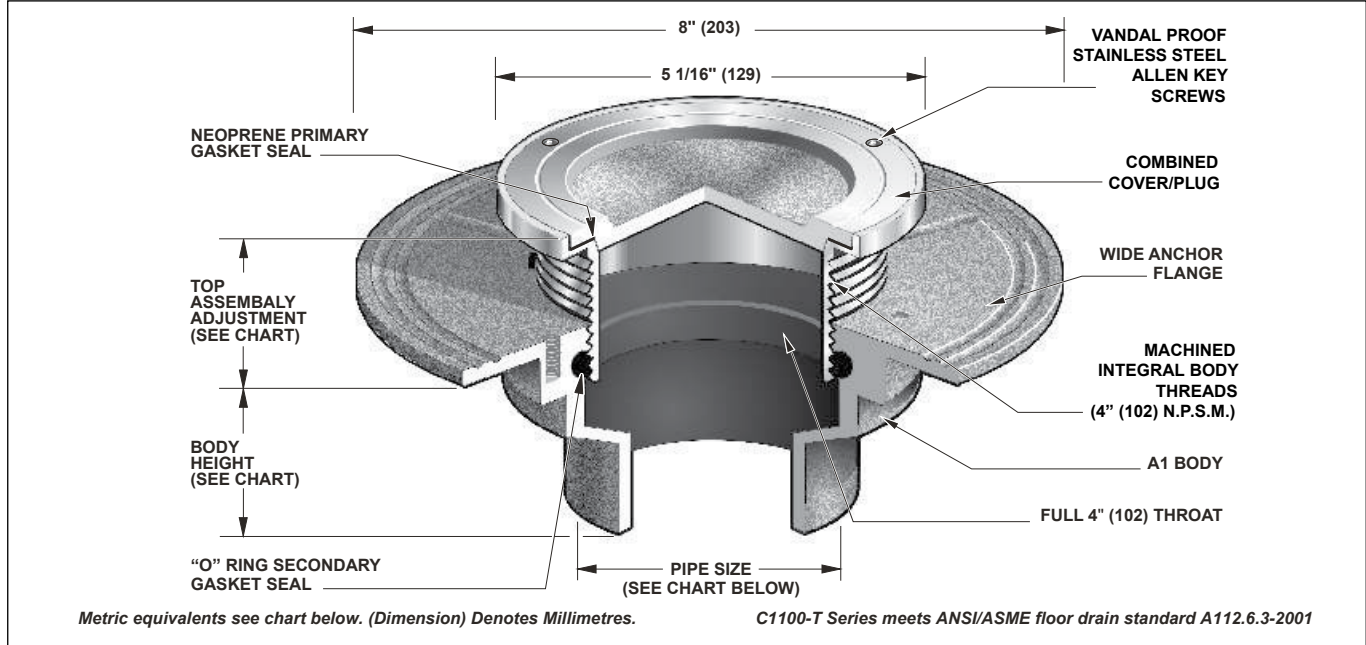

TOP ASSEMBLY DIAMETER	TOP ASSEMBLY ADJUSTMENT		ANSI/ASME RATING		PIPE SIZE	BODY HEIGHT				
	MIN	MAX	LOAD RATING			NO HUB (STANDARD)	PUSH ON (P)	THREADED (T)	INSIDE CAULK (X)	PVC/ABS (-30)/(-31)
			N.B. (-1) Lbs.	S.S. (-3) Lbs.						
5" (127)	1/2" (13)	1 1/4" (32)	Up to 4,999	5,000 to 7,499	2" (51)	3" (76)	3 3/8" (86)	2 1/4" (57)	3 3/4" (95)	2 15/16" (75)
					3" (76)	3" (76)	3 3/8" (86)	2 5/8" (67)	3 3/4" (95)	3 3/4" (95)
					4" (102)	3" (76)	3 3/8" (86)	2 5/8" (67)	3 3/4" (95)	3 3/4" (95)
					5" (127)	3" (76)	--	2 5/8" (67)	3 3/4" (95)	--
					6" (152)	3 1/4" (83)	6 1/2" (165)	--	--	--

Suffix	Description
-1	Nickel bronze top assembly
-3	Heavy duty stainless steel top assembly
-6	Security screws (TR25 Torx & pin)
-11	Acid resistant epoxy coated body
-13	Galvanized body
-15	Extension
-28	Stainless steel body (Type 304)
-30	PVC socket connection body
-31	ABS socket connection body
-34	Secondary closure plug
-90	Threaded side outlet (2", 3", 4") (cast iron only)

-90NH	No hub side outlet (2", 3", 4") cast iron only
-95	Special marking etched into top (SAN for sanitary or GW for Grease Waste)
-BA	Buy American Act compliant product
-C	Membrane clamp
(Standard)	No hub outlet
P	Push on outlet
-PA	Pennsylvania Steel Act compliant product
T	Threaded outlet (2", 3", 4")
X	Inside caulk outlet
-Z	Extended wide elastomeric flange

CALIFORNIA PROPOSITION 65 WARNING. This product contains chemicals known to the State of California to cause cancer and birth defects or other reproductive harm.

Job Name: \_\_\_\_\_ Page No: \_\_\_\_\_  
 Section No: \_\_\_\_\_ Contractor: \_\_\_\_\_  
 Schedule No: \_\_\_\_\_ Purchase Order No: \_\_\_\_\_