

Location: _____



F100

ROUND ADJUSTABLE FLOOR DRAIN WITH FLANGE

Specification: MIFAB Series F100 lacquered cast iron floor drain with anchor flange, and standard satin finished nickel bronze or ductile iron strainer with vandal resistant stainless steel allen key screws.

Function: Used in showers, kitchens, restrooms, and other non-membrane finished areas.

F104-30-5-1

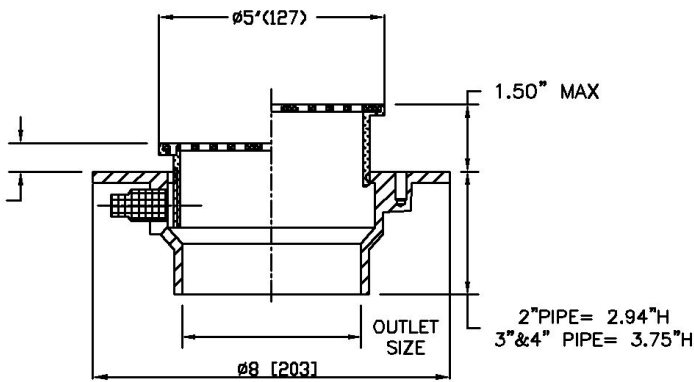
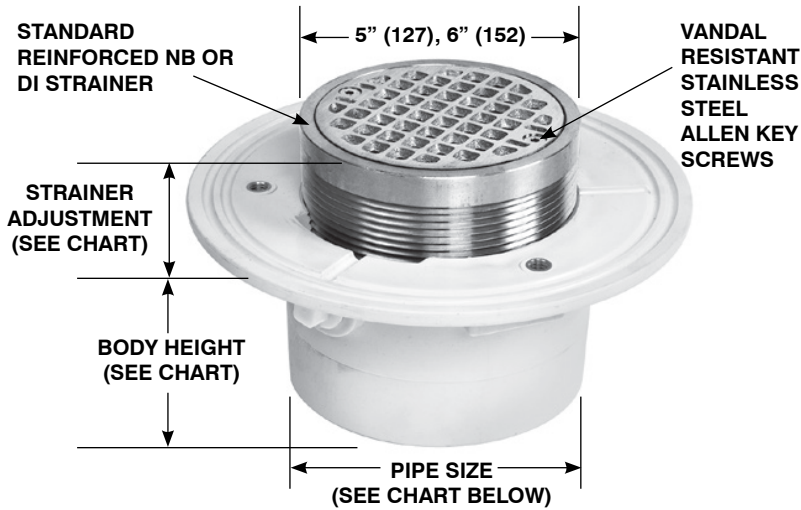

F104-5-1

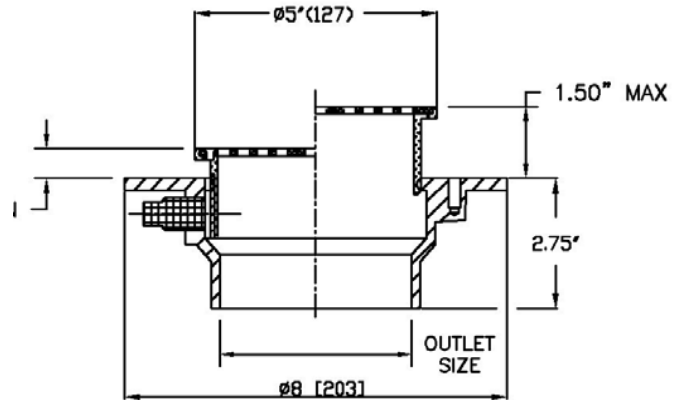
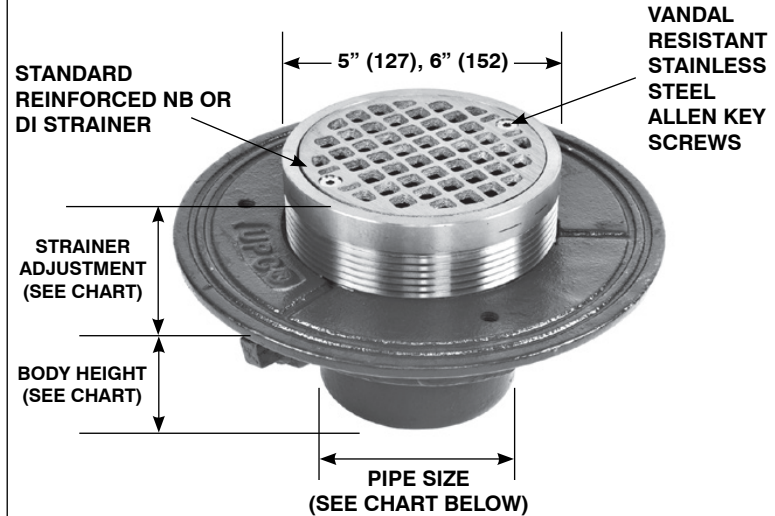

SUFFIX OPTIONAL VARIATIONS

-6 Vandal proof

STRAINER DIAMETER	STRAINER ADJUSTMENT		FREE AREA	ANSI/ASME RATING		PIPE SIZE	NO HUB (STANDARD)	PUSH ON (P)	PVC/ABS (-30)/(-31)
	MIN	MAX		LOAD RATING					
				N.B. (-1)	D.I. (-4)				
5" (127)	1/2" (13)	1 1/2" (38)	8 in ² (5200 ²)	Up to 2,000 Lbs.	Over 10,000 Lbs.	2" (51)	3" (76)	3 3/8" (86)	2 15/16" (75)
6" (152)	11/16" (17)	1 1/2" (38)	9 in ² (5800 ²)	Up to 2,000 Lbs.	--	3" (76)	3" (76)	3 3/8" (86)	3 3/4" (95)
						4" (102)	3" (76)	3 3/8" (86)	3 3/4" (95)

Job Name: _____
 Section No: _____
 Schedule No: _____

Page No: _____
 Contract: _____
 Purchase Order No: _____