

Location: _____



STR

BRONZE STRAINERS -LL

Specification: The "Y" type strainer shall be a bronze body strainer with a brass cap and a stainless steel mess screen. The valve shall be designed so the screen can be cleaned without removal of the valve from the pipe line and shall be equipped with a enclosure plug in the brass clean out cap for the addition of a test gauge or secondary water line.

Ratings:
Maximum Working Pressure: 400 P.S.I. (27.6 bar) WOG @ 210° F (99° C)

Materials:
Bronze Body: Standard UNS-C84400
Retainer Cap: Brass
Cap Gasket: NBR
Standard Screen: 304 Stainless Steel 20 Mesh

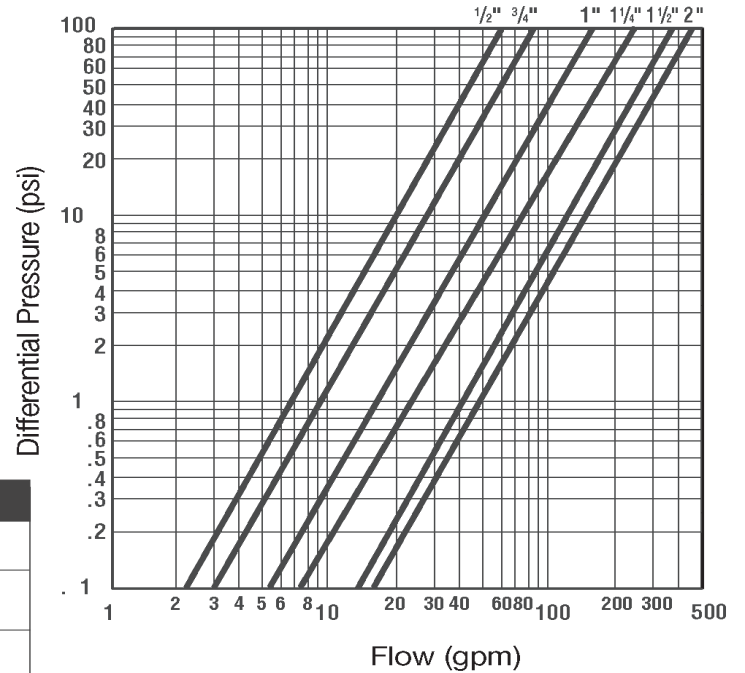
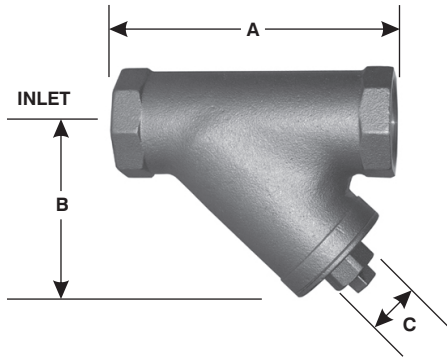

Model No.	STR-SWT	A	B	C
STR.50-SWT-BRZ-LL	1/2" (13)	2 3/4" (70)	1 1/4" (35)	1/4" (6)
STR.75-SWT-BRZ-LL	3/4" (19)	3 3/8" (86)	1 1/2" (43)	1/4" (6)
STR1.00-SWT-BRZ-LL	1" (25)	3 3/4" (95)	2 1/4" (54)	1/2" (13)
STR1.25-SWT-BRZ-LL	1 1/4" (32)	4 1/2" (115)	2 1/2" (65)	1/2" (13)
STR1.50-SWT-BRZ-LL	1 1/2" (40)	5 1/4" (135)	3" (76)	3/4" (19)
STR2.00-SWT-BRZ-LL	2" (51)	6 3/16" (157)	3 1/2" (90)	1" (25)

Model No.	STR-IPS	A	B	C
STR.50-IPS-BRZ-LL	1/2" (13)	2 3/4" (70)	1 1/4" (35)	1/4" (6)
STR.75-IPS-BRZ-LL	3/4" (19)	3 1/4" (80)	1 1/2" (43)	1/4" (6)
STR1.00-IPS-BRZ-LL	1" (25)	3 3/4" (95)	2 1/4" (54)	1/2" (13)
STR1.25-IPS-BRZ-LL	1 1/4" (32)	4 1/2" (115)	2 1/2" (65)	1/2" (13)
STR1.50-IPS-BRZ-LL	1 1/2" (40)	5" (127)	3" (76)	3/4" (19)
STR2.00-IPS-BRZ-LL	2" (51)	6" (152)	3 1/2" (90)	1" (25)

Job Name: _____	Page No: _____
Section No: _____	Contractor: _____
Schedule No: _____	Purchase Order No: _____

BEECO reserves the right to make changes in material and design without formal notice and obligation.

USA: 1-800-387-3880 www.beecobackflow.com CAN: 1-416-679-0380