

Location: \_\_\_\_\_



**MI-600-50**

**TRAP SEAL  
PRIMER ADAPTOR**

**Specification:** MIFAB® Series MI-600-50 lacquered cast iron trap seal primer adaptor with primer tapping boss with 1/2" (13) I.P.S. tapping for installation between floor drain and deep seal trap.

**Function:** Typically used as a trap seal primer connection underneath the outlet of a floor drain, area drain or floor sink. The top of the MI-600-50 product is either 2", 3" or 4" no hub outlet connection size so that it can match any 2", 3" or 4" no hub or push on outlet drain or floor sink connection.

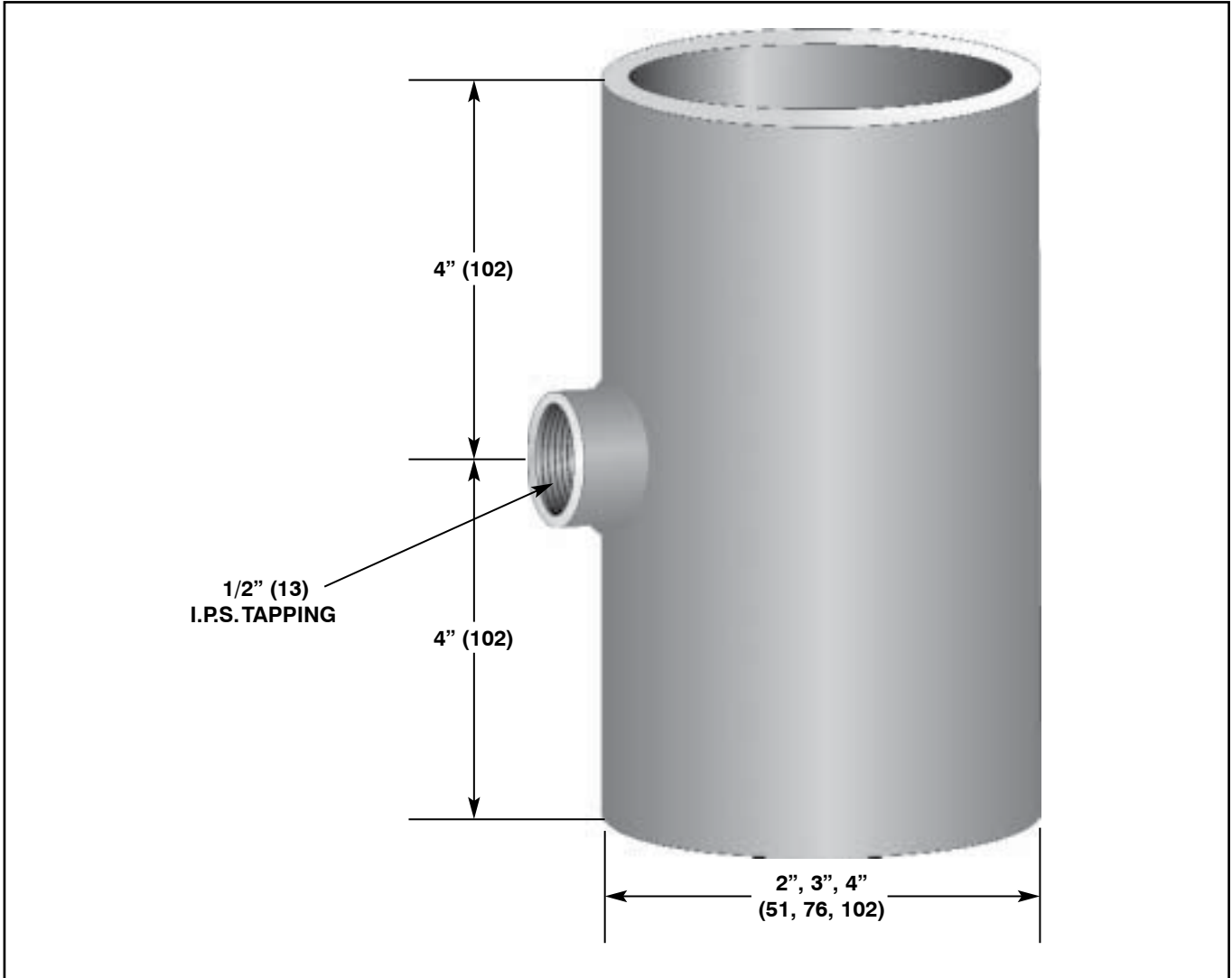

Metric equivalents see chart below. (Dimension) Denotes Millimetres

MODEL NO.	PIPE SIZE (No Hub)
MI-602-50	2"
MI-603-50	3"
MI-604-50	4"

SUFFIX    OPTIONAL VARIATIONS  
-13        Galvanized

CALIFORNIA PROPOSITION 65 WARNING. This product contains chemicals known to the State of California to cause cancer and birth defects or other reproductive harm.

Job Name: \_\_\_\_\_ Page No: \_\_\_\_\_  
Section No: \_\_\_\_\_ Contractor: \_\_\_\_\_  
Schedule No: \_\_\_\_\_ Purchase Order No: \_\_\_\_\_

Location: \_\_\_\_\_



**MI-600-50**

**TRAP SEAL  
PRIMER ADAPTOR**

### **TRAP SEAL PRIMER TROUBLESHOOTING**

Following are some things to trouble shoot when it comes to our M-500 Series of Trap Seal Primers (M1-500, M2-500, M-500).

**1) What is the line pressure for the Installation?**

The M-500 Series will work in 35-80psi.

**2) How far away is the trap seal primer from the source of the pressure drop?**

Anything farther away than 20 feet is an issue, as the farther the primer is away from the source of the pressure drop, the less likely it will sense it and work.

**3) What is the pressure drop where the primer is?**

MIFAB's M-500 Series of primers will work with as little as 3 psi in pressure drop. With today's low flow and consumption faucets, there is less pressure drop being created when the faucets and toilets are used.

**4) Water hammer arrestors on the line can also affect pressure drop in the line.**

It would be best to get a pressure reading where the trap primer is installed. The M-500 series needs a fast, sharp pressure drop to activate. The long pipe run to the trap primer and the water hammer arrestor may not be allowing the trap primer to function properly.

**5) Look at the gauge fluctuation**

Is it a quick and sharp pressure drop? Or did it gradually drop? The trap primers need a quick pressure drop to activate. A slow gradual pressure drop may not be enough to activate the M-500. That is why we state that they should be as close to the pressure drop source as possible. The M1-500 has the most buoyant cartridge and should perform the best. If the trap primer looked good and was filled with water then it is the rate of the pressure drop that is causing the issue.

**Also refer to the copy in the Trap Seal Primer section in the MPB-2015-USA List Price book.**

CALIFORNIA PROPOSITION 65 WARNING. This product contains chemicals known to the State of California to cause cancer and birth defects or other reproductive harm.

Job Name: \_\_\_\_\_ Page No: \_\_\_\_\_  
Section No: \_\_\_\_\_ Contractor: \_\_\_\_\_  
Schedule No: \_\_\_\_\_ Purchase Order No: \_\_\_\_\_